

# **SINGER**

## **1500-2**

Form 19919

(547)

Printed in U. S. A.

# LIST OF PARTS



FOR FAMILY SHOPS

## MACHINE No. 1500-2

---

THE SINGER MANUFACTURING COMPANY

## INSTRUCTIONS FOR OILING

---

When in continuous use, oil should be applied at least four times a day to all oil holes and parts in movable contact above and below the machine bed. Keep all wicking saturated with oil.

Use only MANUFACTURING SEWING MACHINE OIL, HEAVY GRADE, or MANUFACTURING SEWING MACHINE OIL, HEAVY GRADE--STAINLESS OIL, sold by The SINGER SEWING MACHINE COMPANY.

At least four times each day apply ONE DROP of oil to the bobbin case holder bearing in the sewing hook race.

## INDEX

---

	Page
Accessories.....	16
Binders.....	16 to 25
Bobbin Winders.....	25
Corders.....	26
Edge Folders.....	27
Edge Guide (Roller).....	28
Face Plate Thread Lubricator.....	29
Feed Dogs and Throat Plates.....	29
Finger Guards.....	30
Fittings.....	46 to 49
Guides (Miscellaneous).....	31
Hemmers.....	31 to 35
Hemstitcher.....	35
Knee Lifters.....	35 to 37
Lap Seam Feller.....	37
Machine Base.....	37
Machine No. 1500-2.....	7
Numerical List of Parts.....	51
Piping Attachment.....	38
Presser Feet.....	38 to 41
Presser Foot and Extensions.....	41
Quilters.....	41
Ruffler.....	42
Seamer.....	43
Thread Stabilizer.....	43
Thread Unwinder.....	43
Tubular Trimming Attachment.....	44
Tuckers.....	44 to 46

From the library of: Diamond Needs Corp

## INSTRUCTIONS FOR ORDERING

In ordering from this list, use ONLY the part NUMBER in the FIRST column.

The number stamped on a Sewing Machine Part is in every case the number of the single part only.

Every combination of parts sent out as such has its specific number, which, although not stamped on the parts, must be used when ordering the combination.

Each number always indicates the SAME PART in whatever list it appears, or for whatever machine.

The letters after some of the numbers indicate the style of finish only, as follows:

A-Hardened, Polished, Nickel Plated and Buffed  
A.A-Buffed and Chromium Plated  
A.B-Hardened, Polished, Buffed and Chromium Plated  
A.C-Brown Baking Enamel Finish  
A.D-Gray Baking Enamel Finish  
A.E-Hardened, Bright Rumbled and Nickel Plated  
A.F-Hardened, Bright Rumbled, Nickel Plated, Bright Rumbled and Chromium Plated  
A.G-Alumilite, Plain  
A.H-Alumilite, Dyed  
A.J-Polished, Nickel Plated and Chromium Plated  
A.K-Hardened, Polished, Nickel Plated and Chromium Plated  
A.L-Heat Treated for Toughness  
B-Polished, Nickel Plated and Buffed  
C-Hardened Only  
C.R-Hardened and Merlized  
D-Polished Only  
E-Soft, Not Polished  
F-Hardened and Polished  
F.J-Hardened, Polished and Nickel Plated  
G-Bright Rumbled and Nickel Plated  
H-Blued  
J-Nickel Plated Only  
K-Hardened and Nickel Plated  
L-Brass Plated  
M-Oxidized  
N-Japanned, Dull  
P-Japanned, Bright  
P.P-Wrinkle Finish  
R-Merlized  
S-Cadmium Plated  
T-Copper Plated  
T.A-Hardened, Polished, Copper and Nickel Plated and Buffed  
T.B-Copper and Nickel Plated and Polished  
T.J-Copper and Nickel Plated Only  
T.K-Hardened, Copper and Nickel Plated  
T.L-Copper and Brass Plated  
T.M-Copper Plated and Oxidized

## INSTRUCTIONS FOR ORDERING - Continued

U-Zinc Plated  
V-Silver Plated  
W-Polished and Nickel Plated  
X-Black Oxide, for Iron and Steel  
X.C-Hardened and Black Oxide, for Iron or Steel  
Y-Black Nickel Plated Only  
Z-Chromium Plated  
Z.A-Hardened, Polished, Nickel Plated, Buffed and Chromium Plated  
Z.B-Polished, Nickel Plated, Buffed and Chromium Plated  
Z.C-Hardened and Chromium Plated  
Z.D-Polished and Chromium Plated  
Z.G-Bright Rumbled, Nickel Plated, Bright Rumbled and Chromium Plated  
Z.J-Nickel and Chromium Plated  
Z.T-Copper and Chromium Plated

These letters MUST BE USED when they appear in the list; and AFTER the number as in the list.

In this series:

1 to 1500, 50001 to 51500 and 140001 to 142000 are Screw Numbers  
1501 to 1800 and 51501 to 51800 are Nut Numbers  
1801 to 2000 and 51801 to 52000 are Roller Numbers  
2001 to 50000 and 52001 to 140000 and 142001 to 190000 are Sewing Machine Parts, 190001 and upward are numbers of Electrical Parts.

The figures in the second column refer only to the plates, illustrating the parts, and are NOT TO BE USED in ordering.

Parts marked with an asterisk (\*) are furnished only when repairs are made at factory.

From the library of the American Needle Corp.

LIST OF PARTS COMPLETE  
FOR

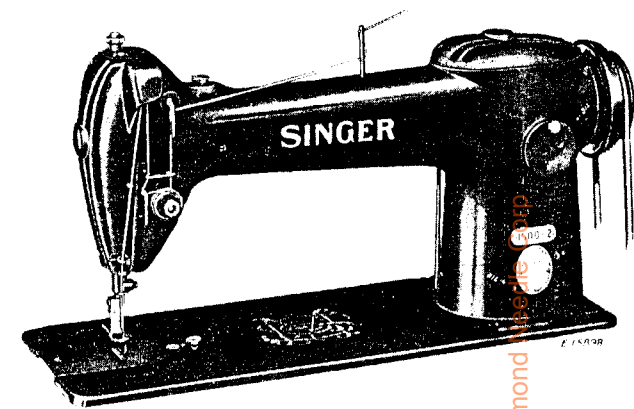

Genuine "SINGER" Needles should be used  
in "SINGER" Machines.  
These Needles and their Containers  
are marked with the  
Company's Trade Mark "SIMANCO" 1

Needles in Containers marked  
"FOR SINGER MACHINES"  
are NOT "SINGER" made needles. 2

MACHINE No. 1500-2

FOR TAILOR WORK. FOR ELECTRIC DRIVE. MAXIMUM  
STITCH 5 1/2 TO THE INCH. PRESSER BAR LIFT 3/8 INCH.  
NEEDLE BAR STROKE 1 15/32 INCHES. THREE PLAIN BEAR-  
INGS FOR THE ARM SHAFT. SPEED 3000 R. P. M.

No.	Plate	Name
*144751P	-----	Arm with 15404, 144752 to 144754 and two 143176.....
Note: Due to the accuracy required for gear alignment, Arm cannot be supplied sepa- rately and can only be sent out as a unit, Arm and Bed assembled.		
8582	24326	Arm Dowel Pin (2).....
50608R	24326	" Hole Plug Screw (back of arm)..
68350	24326	" Oil Cup (spring lid) for oiling Arm Shaft (horizontal) Front Bearing.....
56006	24326	Arm Oil Cup (spring lid) Oil Pad (braided cotton).....

From the Library of: Diamond Jubilee EP

No.	Plate	Name
54897	24326	Arm Oil Cup (ball type) for oiling Arm Shaft (horizontal) Back Bearing.....
144752	24326	Arm Oil Tube for oiling Oil Wick Holder complete.....
144753	24326	Arm Oil Tube for oiling Arm Shaft (upright) Bearing (lower).....
144754	24326	Arm Oil Tube for oiling Rotating Hook Shaft (back) Bearing.....
868E	24326	Arm Screw (left) (2).....
140332E	24326	" " (right) (2).....
144755	24326	" Shaft (horizontal).....
144756	-----	" " " 144755 with 144792.....
144758	24326	Arm Shaft (horizontal) Bushing (center) with 52263 and 144759.
52263	24326	Arm Shaft (horizontal) Bushing (center) Oil Pad (felt).....
144759	24326	Arm Shaft (horizontal) Bushing (center) Oil Wick (braided cotton).....
140296AL	24326	Arm Shaft (horizontal) Bushing (center) Set Screw.....
144761	24326	Arm Shaft (horizontal) Flanged Bushing (back) with 52289 and 144762.....
52289	24326	Arm Shaft (horizontal) Flanged Bushing (back) Oil Pad (felt)..
144762	24326	Arm Shaft (horizontal) Flanged Bushing (back) Oil Wick (braid- ed cotton).....
140297AL	24326	Arm Shaft (horizontal) Flanged Bushing (back) Set Screw.....
144764	24326	Arm Shaft (horizontal) Flanged Bushing (front) with 52194, 52289, 144833 and 144834.....
52289	24326	Arm Shaft (horizontal) Flanged Bushing (front) Oil Pad (thick) (felt).....
52194	-----	Arm Shaft (horizontal) Flanged Bushing (front) Oil Pad (thin) (felt).....
144834	24326	Arm Shaft (horizontal) Flanged Bushing (front) Oil Pad Retain- er.....
144833	24326	Arm Shaft (horizontal) Flanged Bushing (front) Oil Wick (braided cotton).....
140331AL	24326	Arm Shaft (horizontal) Flanged Bushing (front) Set Screw.....
144765	24326	Arm Shaft (upright).....
143014	24326	" " " Bevel Gear (lower) right hand spiral with two 1259AL.....

Note: When ordering No. 143014 Class No. of Ma-  
chine must be stated.

No.	Plate	Name
1259AL	24326	Arm Shaft (upright) Bevel Gear (lower) Set Screw (2).....
143015	24326	Arm Shaft (upright) Bevel Gear (upper) left hand spiral with two 1259AL.....
Note: When ordering No. 143015 Class No. of Ma- chine must be stated.		
1259AL	24326	Arm Shaft (upright) Bevel Gear (upper) Set Screw (2).....
144767	24326	Arm Shaft (upright) Bushing (lower) with 52280 and 144768.....
52280	24326	Arm Shaft (upright) Bushing (lower) Oil Pad (felt).....
144768	24326	Arm Shaft (upright) Bushing (lower) Oil Wick (braided cotton).....
140298AL	24326	Arm Shaft (upright) Bushing (lower) Set Screw.....
144770	24326	Arm Shaft (upright) Bushing (upper) with 52280 and 144768.....
52280	24326	Arm Shaft (upright) Bushing (upper) Oil Pad (felt).....
144768	24326	Arm Shaft (upright) Bushing (upper) Oil Wick (braided cotton).....
140298AL	24326	Arm Shaft (upright) Bushing (upper) Set Screw.....
144771	24326	Arm Side Cover (front).....
50684W	24326	" " " Thumb Screw.....
143018	24326	" " " Shield.....
219J	24326	" " " Screw.....
52239	24327	" Spool Pin and Thread Eyelet....
8879	24327	" " " Washer (cloth).....
142755	24328	" Top Cover for 142756.....
142756	-----	" " " 142755 with 144777 and 144778, for 142759.....
142757	24328	Arm Top Cover for 142758.....
142758	-----	" " " 142757 with 144777 and 144778, for 142760.....
144776	24328	Arm Top Cover Gasket (cork).....
144777	24328	" " " Oil Tube (long) with 52184, for oiling Feed Lifting Rock Shaft Connecting Rod.....
144778	24328	Arm Top Cover Oil Tube (short) with 52184, for oiling Feed Rock Shaft Connecting Rod.....
52184	-----	Arm Top Cover Oil Tube Packing (wick) (2).....
51369R	24328	Arm Top Cover Screw (2).....
143244	24328	Arm Top Cover Spool Pin and Spool Rest, 3 1/2 in. long, for 142760.....
143207	24328	Arm Top Cover Stitch Regulator Plunger.....
140317	24328	Arm Top Cover Stitch Regulator Plunger Hole Plug Screw for plugging the Plunger hole when the Plunger is removed to pre- vent tampering with the stitch set.....

No.	Plate	Name
64519	24328	Arm Top Cover Stitch Regulator Plunger Spring.....
218J	24328	Arm Top Cover Stitch Regulator Plunger Stop Screw.....
142759	24328	Arm Top Cover with Stitch Regulator Plunger complete, Nos. 218J, 64519, 142756 and 143207.....
Note: No. 142759 is regularly furnished with this Machine.		
142760	24328	Arm Top Cover with Stitch Regulator Plunger complete, when a longer Spool Pin is required, Nos. 218J, 64519, 142758, 143207 and 143244.....
143363	24328	Balance Wheel (disc, power) with two 51283AL, for "V" belt.....
51283AL	24328	Balance Wheel Set Screw (2).....
*144781P	-----	Bed
Note: Due to the accuracy required for gear alignment, Bed cannot be supplied sepa- rately and can only be sent out as a unit, Arm and Bed assembled.		
12431X	24327	Bed Slide
4307	24327	" " Spring
725X	24327	" " " Screw (2)
12432	24327	Bed Slide complete, Nos. 4307, 12431X and two 725X.....
144827	-----	Combination of Feed and Stitch Regulator Parts, Nos. 143123, 143134, 143293, 144785, 144788 and 144821.....
143293	-----	Dummy Shaft for 144827.....
143228	24327	Face Plate.....
143229	24327	" " Thread Guard (lower)....
50117J	24327	" " " " " " " Screw.....
143230	24327	Face Plate Thread Guard (upper)....
50117J	24327	" " " " " " " Screw.....
143231	24327	Face Plate complete, Nos. 143228 to 143230 and two 50117J.....
140061J	24327	Face Plate Screw (lower).....
140050J	24327	" " " " (upper).....
143030	24330	Feed Bar.....
51220AL	24330	" " Adjusting Screw (2).....
1607C	24330	" " " " Nut (2)....
143185	24330	" " Body with two each 1607C and 51220AL.....
704C	24330	Feed Bar Body Screw.....
143186	24330	" " Shank.....
143187	24330	Feed Bar (tilting adjustable) com- plete, Nos. 704C, 143185 and 143186.....
Note: Feed Bar No. 143030 is regularly furnished with this machine.....		
313C	24330	Feed Bar Screw Center (2).....

No.	Plate	Name
56813	-----	Feed Bar Screw Center 313C with 1519J (2).....
1519J	24330	Feed Bar Screw Center Nut (2).....
44252	24327	" Dog, 12 teeth (12 teeth to the inch) for 44256.....
50117AL	24327	Feed Dog Screw (2).....
143123	24326	" Eccentric with 1375AL and two 1036AL.....
1375AL	24326	Feed Eccentric Body Position Screw..
1036AL	24326	" " " Set Screw (2)..
140256AL	24326	" " Stop Screw (7 stitch).....
140257AL	24326	Feed Eccentric Stop Screw (5 1/2 stitch).....
140258AL	24326	Feed Eccentric Stop Screw (14 stitch).....
Note: No. 140257 is regularly furnished with this Machine.....		
144782	24326	Feed Lifting Eccentric and Arm Shaft (horizontal) Bevel Gear, right hand spiral, with 1259AL, 140333AL and 143088.....
140333AL	24326	Feed Lifting Eccentric Position Screw.....
1259AL	24326	Feed Lifting Eccentric Set Screw...
144783	24330	" " Rock Shaft.....
144784	-----	Feed Lifting Rock Shaft complete, Nos. 52265 and 144783.....
144785	24326	Feed Lifting Rock Shaft Connecting Rod.....
140230C	24326	Feed Lifting Rock Shaft Connecting Rod Hinge Screw.....
1518J	24326	Feed Lifting Rock Shaft Connecting Rod Hinge Screw Nut.....
52265	24330	Feed Lifting Rock Shaft Crank with 157J and 52267.....
157J	24330	Feed Lifting Rock Shaft Crank Clamping Screw.....
52266	24330	Feed Lifting Rock Shaft Crank Slide Block.....
52267	-----	Feed Lifting Rock Shaft Crank Slide Block 52266 with 125060.....
125060	24330	Feed Lifting Rock Shaft Crank Slide Block Stud.....
50191C	24330	Feed Lifting Rock Shaft Screw Center (2).....
52097	-----	Feed Lifting Rock Shaft Screw Center 50191C with 1513J (2)...
1513J	24330	Feed Lifting Rock Shaft Screw Center Nut (2).....
144786	24330	Feed Rock Shaft.....
144787	-----	Feed Rock Shaft complete, Nos. 144786 and 144789.....
144788	24326	Feed Rock Shaft Connecting Rod....
140230C	24326	" " " " " Hinge Screw.....

No.	Plate	Name
1518J	24326	Feed Rock Shaft Connecting Rod Hinge Screw Nut.....
144789	24330	Feed Rock Shaft Crank with 157J....
157J	24330	" " " " Clamping Screw.....
50191C	24330	Feed Rock Shaft Screw Center (2)...
52097	-----	" " " " 50191C with 1513J (2).....
1513J	24330	Feed Rock Shaft Screw Center Nut (2).....
142770	24326	Gear Case (lower) (two pieces) with 140184E and three 145E.....
140184E	24326	Gear Case (lower) Plug Screw.....
145E	24326	" " " Screw (3).....
142766	24326	" " (upper) (two pieces) with 50668E and 50669E.....
142767	24326	Gear Case (upper) Oil Cup.....
142768	24326	" " " " 142767 with 130911.....
130911	24326	Gear Case (upper) Oil Cup Oil Wick (braided cotton).....
50668E	24326	Gear Case (upper) Screw (long)....
50669E	24326	" " " " (short)....
25878	24327	Guide.....
50190W	24327	" Thumb Screw.....
127243	24329	Needle Bar (hollow).....
127244	-----	" " 127243 with 51229J, 127245 and 127246.....
143251	24329	Needle Bar Bushing (lower).....
1133E	24329	" " " " Set Screw.....
52014	24329	Needle Bar Bushing (upper).....
1133E	24329	" " " " Set Screw.....
127231	24329	Needle Bar Connecting Link with 52207.....
144819	-----	Needle Bar Connecting Link 127231 with 143057.....
775E	24329	Needle Bar Connecting Link Cap Screw.....
52207	24329	Needle Bar Connecting Link Lubri- cating Pad (wood).....
143057	24329	Needle Bar Connecting Stud with 207E.....
207E	24329	Needle Bar Connecting Stud Clamping Screw.....
143058	24329	Needle Bar Connecting Stud Slide Block.....
144792	24326	Needle Bar Crank with 1036AL, 1065AL and 140327AL.....
1065AL	24326	Needle Bar Crank Position Screw....
127245	24329	" " Thread Guard.....
51229J	24329	" " " " Screw.....
127246	24329	" Clamp with 140119F.....
140119F	24329	" " Screw.....
56015	24326	Oil Tube for 144793.....

No.	Plate	Name
144793	24326	Oil Tube Bracket with 56015, for oiling Arm Shaft (upright) Bearing (upper).....
50156E	24326	Oil Tube Bracket Screw.....
143197	24326	" Wick for oiling Needle Bar Con- necting Link, Thread Take-up Lever, Thread Take-up Lever Hinge Bearing and Thread Take-up Lever Link for 144823 (2).....
144823	24326	Oil Wick Holder with two 143197....
144795	24326	Oil Wick Holder complete, Nos. 144796 and 144823.....
144796	24326	Oil Wick Holder Cap for 144795....
140232J	24326	" " " Screw.....
12391	24329	Presser Bar (hollow).....
143184	24329	" " Bushing (lower).....
1133E	24329	" " " " Set Screw.....
52338	24329	Presser Bar Guide Bracket with 223C and 453AL.....
453AL	24329	Presser Bar Guide Bracket Set Screw
5990	24329	" " Lifter.....
143079	24329	" " " Hinge Stud.....
448AL	24329	" " " " Set Screw.....
12327	24329	Presser Bar Lifting and Releasing Lever Bracket.....
12139	24329	Presser Bar Spring.....
11170	24329	" " " Washer.....
20458	24329	" Foot (solid) for general and tailor work.....
140390AL	24329	Presser Foot Screw.....
688W	24329	Pressure Regulating Thumb Screw....
144828	24329	Rotating Hook with three 1253AL....
144829	-----	" " 144828 with 127102 and four 1053E.....
144830	-----	Rotating Hook 144829 with 40274, 143252 and three 1367E.....
144831	-----	Rotating Hook 144829 with 40274 and three 1367E (for agents only)..
144832	24329	Rotating Hook 144830 with 52237....
40264	24329	" " Bobbin.....
52235	24329	" " " Case.....
52236	-----	" " " " 52235 with 591F, 1380E and 40394....
40392	24329	Rotating Hook Bobbin Case Latch....
125320	24329	" " " " " Lever.....
2974	24329	Rotating Hook Bobbin Case Latch Lever Fulcrum Pin.....
2975	24329	Rotating Hook Bobbin Case Latch Spring.....
592E	24329	Rotating Hook Bobbin Case Latch Stop Screw.....
40393	24329	Rotating Hook Bobbin Case Hinge, Nos. 2974, 40392 and 125320....



No.	Plate	Name
591F	24329	Rotating Hook Bobbin Case Tension Regulating Screw.....
40394	24329	Rotating Hook Bobbin Case Tension Spring.....
1380E	24329	Rotating Hook Bobbin Case Tension Spring Screw.....
52237	24329	Rotating Hook Bobbin Case complete, Nos. 592E, 2975, 40393 and 52236.....
143253	-----	Rotating Hook Bobbin Case 52237 with 143252.....
143252	24329	Rotating Hook Bobbin Case Holder...
52018	24330	" " " " " " Position Bracket.....
704J	24330	Rotating Hook Bobbin Case Holder Position Bracket Screw.....
40274	24329	Rotating Hook Section.....
1367E	24329	" " " Screw (3)....
1253AL	24329	" " Set Screw (3).....
144797	24330	" " Shaft.....
144798	24330	" " Bevel Gear (left hand spiral) with two 1259AL.....
1259AL	24330	Rotating Hook Shaft Bevel Gear Set Screw (2).....
144800	24330	Rotating Hook Shaft Bushing (back) with 52280 and 144801.....
52280	24330	Rotating Hook Shaft Bushing (back) Oil Pad (felt).....
144801	24330	Rotating Hook Shaft Bushing (back) Oil Wick (braided cotton).....
140261AL	24330	Rotating Hook Shaft Bushing (back) Set Screw.....
144803	24330	Rotating Hook Shaft Bushing (front) with 144801 and two 52280.....
52280	24330	Rotating Hook Shaft Bushing (front) Oil Pad (felt) (2).....
144801	24330	Rotating Hook Shaft Bushing (front) Oil Wick (braided cotton).....
142008	24330	Rotating Hook Shaft Bushing (front) Oil Cup.....
140261AL	24330	Rotating Hook Shaft Bushing (front) Set Screw.....
127102	24329	Rotating Hook Thread Guard.....
1053E	24329	" " " " Screw (4).....
144821	-----	Set of Mated Gears complete for upper shaft, Nos. 143015, 143087 and 144782.....
144822	-----	Set of Mated Gears complete for lower shaft, Nos. 143014 and 144798.....
52337	24329	Slack Thread Regulator.....
223C	24329	" " " Set Screw...
143085	24326	Stitch Regulator.....

No.	Plate	Name
143134	-----	Stitch Regulator 143085 with 140380E, 143086 and 143089.....
143086	24326	Stitch Regulator Locking Slide.....
143087	24326	Stitch Regulator Locking Slide Ratchet Wheel.....
143088	24326	Stitch Regulator Locking Slide Ratchet Wheel Pin.....
143089	24326	Stitch Regulator Locking Slide Spring.....
140380E	24326	Stitch Regulator Locking Slide Spring Screw.....
2102	24327	Tension Disc (2).....
1560C	24327	" Regulating Thumb Nut.....
32572	24327	" Releasing Disc.....
52445	24327	" " Lever.....
12398	24327	" " " Hinge Pin..
12329	24327	" " " Spring.....
32574	24327	" " Pin.....
2103	24327	" Spring.....
50304C	24327	" Stud.....
52098	-----	" " 50304C with 1560C.....
50305C	24327	" " Set Screw.....
52397	24327	Tension Complete, Nos. 2103, 32572, 32574, 52083, 52098, 52394 and two 2102.....
143135	24327	Thread Guard (side of arm).....
52454	24327	" Retainer.....
624AL	24327	" " Set Screw.....
144804	24329	Thread Take-up complete, Nos. 143097, 144806 and 144808.....
144805	24329	Thread Take-up Crank.....
144806	-----	" " " 144805 with 775E and 144819.....
140327AL	24326	Thread Take-up Crank Clamping Screw
1036AL	24326	" " " Position Screw
143241	24326	" " " Wearing Plate.
144807	-----	" " Lever with 52130....
52023	24329	" " " Hinge Stud....
143096	24329	" " " Link.....
143097	24329	" " " Hinge Stud.....
435AL	24329	Thread Take-up Lever Link Hinge Stud Set Screw.....
52130	24329	Thread Take-up Lever Thread Eyelet Bushings.....
144808	-----	Thread Take-up Lever complete, Nos. 52023, 143096 and 144807.....
52394	24327	Thread Take-up Spring.....
52083	24327	" " " Regulator with 50305C.....
443AL	24327	Thread Take-up Spring Regulator Set Screw.....
44256XC	24327	Throat Plate (large needle hole) for 44252.....
691XC	24327	Throat Plate Screw (2).....
144809	24023	Drip Pan with four 1 in. wire nails
*15404	-----	Trade Mark.....
143176	-----	" " Rivet (2).....

**ACCESSORIES**

No.	Plate	Name
12361	----	Machine Hinge Connection (2).....
41564	24331	Machine Rest Pin (wood) 4 in. long.
120342	24331	Oiler (copper plated) with 120343..
120343	24331	" Spout, 3 1/2 in. long.....
26026	24331	Screw Driver (large).....
26485	24331	" " (small).....
8909	24331	Wrench for 1513 and 1518.....
8908	24331	" " 1519 and 1520.....

**BINDERS**

WHEN ORDERING BINDERS SEND SAMPLE OF THE

BINDING AND MATERIAL TO BE BOUND

**BINDER (Adjustable)**

SIZE 1

No.	Plate	Name
25644	22912	Bed.....
25646	22912	Folder Guide (lower) with 25855....
25855	----	" " " Screw Stud....
25647	22912	" " (upper).....
1577D	22912	" " " Thumb Nut.....
25648	22912	Pressure Spring.....
334J	22912	" " " Screw.....
7071	22912	" " " Washer.....
25650	22912	Binder complete, Nos. 334J, 1577D, 7071, 25644 and 25646 to 25648.
190J	22912	Binder Screw.....

**BINDER (Adjustable)**

SIZE 2

THIS BINDER IS THE SAME AS 25650 WITH THE

FOLLOWING EXCEPTIONS:

No.	Plate	Name
25651	22912	Bed, in place of 25644.....
25653	22912	Binder complete, Nos. 334J, 1577D, 7071, 25646 to 25648 and 25651.

**BINDER (Adjustable)**

SIZE 3

THIS BINDER IS THE SAME AS 25650 WITH THE

FOLLOWING EXCEPTIONS:

No.	Plate	Name
25654	22912	Bed, in place of 25644.....
25656	22912	Binder complete, Nos. 334J, 1577D, 7071, 25646 to 25648 and 25654.

**BINDER (Adjustable)**

FOR SOFT HATS

No.	Plate	Name
36456	22913	Bed.....
36457	22913	Folder.....
25672	22913	" Slide Carrier with 656E.....
656E	22913	" " " Adjusting Screw.....
1536D	22913	Folder Slide Carrier Adjusting Thumb Nut.....
25673	22913	Folder Slide Carrier Adjusting Thumb Nut Guide.....
401E	22913	Folder Slide Carrier Adjusting Thumb Nut Guide Screw.....
334J	22913	Folder Slide Carrier Screw (2).....
36459	22913	Guide (back, lower).....
36460	22913	" (back, upper).....
233J	22913	" (back) Screw.....
36461	22913	" (front, lower).....
36462	22913	" (front, upper).....
233J	22913	" (front) Screw.....
25677	22913	Pressure Spring.....
334J	22913	" " " Screw.....
36463	22913	Binder complete, Nos. 401E, 1536D, 25672, 25673, 25677, 36456, 36457, 36459 to 36462, two 233J and three 334J.....
190J	22913	Binder Screw.....
28713	22913	Presser Foot, for soft hat binding for 36463.....

Note: Presser Foot 28713 is used with, but not included in 36463.....

**BINDER (Adjustable)**

FOR SLEEVE FACINGS ON MILITARY COATS

No.	Plate	Name
120165	22913	Binder.....
28972	22913	Arm.....
940D	22913	" Hinge Screw.....

No.	Plate	Name
28973	22913	Hinge Plate.....
51224W	22913	Shank Thumb Screw.....
7071	22913	" " " Washer.....
120166	22913	Binder complete, Nos. 940D, 7071, 28972, 28973, 51224W and 120165

**BINDER (Boston)**

No.	Plate	Name
120955	22913	Binder (Boston) on Shank.....

**BINDER (English)**FOR BINDING UP TO  $\frac{9}{16}$  INCH

No.	Plate	Name
121444	22914	Feed Dog, 13 teeth (16 teeth to the inch) for 121445.....
25721	22914	Folder.....
207F	22914	" Screw.....
7071	22914	" " Washer.....
25983	22914	Presser Foot.....
25722	22914	Ribbon Tension.....
190J	22914	" " Screw.....
7071	22914	" " " Washer.....
121445XC	22914	Throat Plate for use with 121444...
26250	22914	Binder complete, Nos. 190J, 207F, 25721, 25722, 25983, 121444, 121445XC and two 7071.....

**BINDER (English)**

LARGE "D" FEED

THIS BINDER IS THE SAME AS 26250 WITH THE

FOLLOWING EXCEPTIONS:

No.	Plate	Name
12370	22914	Feed Dog, 15 teeth (16 teeth to the inch) for use with 26465 and 35741, in place of 121444.....
26465XC	22914	Throat Plate, large needle hole, for use with 12370, in place of 121445.....
35741XC	-----	Throat Plate, small needle hole, for use with 12370, in place of 121445.....
26466	22914	Binder complete, Nos. 190J, 207F, 12370, 25721, 25722, 25983, 26465XC or 35741XC and two 7071

**BINDER (English)**

THIS BINDER IS THE SAME AS 26250 WITH THE

FOLLOWING EXCEPTIONS:

No.	Plate	Name
44252	-----	Feed Dog, 12 teeth (12 teeth to the inch) for use with 28655 and 28656, in place of 121444.....
44253	22915	Feed Dog, 16 teeth (16 teeth to the inch) for use with 28655 and 28656, in place of 121444.....
28655XC	22915	Throat Plate, small needle hole, for use with 44252 and 44253, in place of 121445.....
28656XC	-----	Throat Plate, large needle hole, for use with 44252 and 44253, in place of 121445.....
28657	22915	Binder complete, Nos. 190J, 207F, 25721, 25722, 25983, 28655XC or 28656XC, 44252 or 44253 and two 7071.....

**BINDER (English)**

FOR CUT CLOTH

No.	Plate	Name
19474	22916	Feed Dog, 14 teeth (16 teeth to the inch) for use with 26401.....
25733	22916	Folder, for 1/2 inch binding.....
207F	22916	" Screw.....
7071	22916	" " Washer.....
26400	22916	Presser Foot.....
25734	22916	Ribbon Tension.....
190J	22916	" " " Screw (2).....
7071	22916	" " " Washer (2).....
26401XC	22916	Throat Plate for use with 19474.....
26402	22916	Binder complete, Nos. 207F, 19474, 25733, 25734, 26400, 26401XC, two 190J and three 7071.....

**BINDER (English)**

FOR HEAVY WORK

No.	Plate	Name
121446	22917	Feed Dog (spiked teeth) 13 teeth (10 teeth to the inch) for use with 121447.....
28334	22917	Folder.....
193J	22917	" Screw.....
7071	22917	" " Washer.....

From the library of: Diamond Needle Co.

## BINDERS

No.	Plate	Name
28676	22917	Presser Foot.....
28337	22917	Ribbon Tension.....
233J	22917	" " Screw (2).....
121447XC	22917	Throat Plate for use with 121446....
28678	22917	Binder complete, Nos. 193J, 7071, 28334, 28337, 28676, 121446, 121447XC and two 233J.....

## BINDER (English)

## FOR LIGHT WORK

THIS BINDER IS THE SAME AS 28678 WITH THE

## FOLLOWING EXCEPTIONS:

No.	Plate	Name
121269	22917	Presser Foot, in place of 28676.....
121270	22917	Binder complete, Nos. 193J, 7071, 28334, 28337, 121269, 121446, 121447XC and two 233J.....

## BINDER (English)

## FOR CARPETS

THIS BINDER IS THE SAME AS 28678 WITH THE

## FOLLOWING EXCEPTIONS:

No.	Plate	Name
12370	22915	Feed Dog, 15 teeth (16 teeth to the inch) for use with 28775, in place of 121446.....
28775XC	22915	Throat Plate for use with 12370, in place of 121447.....
28776	22915	Binder complete, Nos. 193J, 7071, 12370, 28334, 28337, 28676, 28775XC and two 233J.....

## BINDER (English)

## FOR AWNINGS

No.	Plate	Name
120434	22916	Feed Dog, 7 teeth (16 teeth to the inch) for use with 120436.....
120433	22916	Folder.....
207F	22916	" Screw.....
7071	22916	" " Washer.....
120435	22916	Presser Foot.....
25722	22916	Ribbon Tension.....
190J	22916	" " Screw.....
7071	22916	" " " Washer.....
120436XC	22916	Throat Plate for use with 120434....
120437	22916	Binder complete, Nos. 190J, 207F, 25722, 120433 to 120436XC and two 7071.....

## BINDERS

## BINDER (English)

## FOR SLIP COVERS AND GENERAL WORK

THIS BINDER IS THE SAME AS 120437 WITH THE

## FOLLOWING EXCEPTIONS:

No.	Plate	Name
120458	22918	Presser Foot, in place of 120435....
120459	22918	Binder complete, Nos. 190J, 207F, 25722, 120433, 120434, 120436XC, 120458 and two 7071.....

## BINDER (English)

No.	Plate	Name
120124	22918	Feed Dog, 6 teeth (16 teeth to the inch) for use with 120126.....
120120	22918	Folder with 665J and 120121.....
120121	22918	" Guide.....
665J	22918	" " Screw.....
220J	22918	" Screw.....
7806	22918	" " Washer.....
120125	22918	Presser Foot.....
120123	22918	Ribbon Tension.....
190J	22918	" " Screw (2).....
7071	22918	" " " Washer (2).....
120126XC	22918	Throat Plate for use with 120124....
120127	22918	Binder complete, Nos. 220J, 7806, 120120, 120123 to 120126XC and two each 190J and 7071.....

## BINDER (Transverse) ON SHANK

## FOR FOLDED OR UNFOLDED BIAS BINDING

## (WITH TAPE REEL)

## FOR GENERAL WORK

## FOR 3/4 IN., 7/8 IN. AND 1 IN. TAPE

No.	Plate	Name
121167	22919	Binder Folder on Shank.....
43525	22919	Binder Steady Pin.....
51097J	22919	" Thumb Screw.....
3146	22919	" " " Washer.....
121397	22919	Feed Dog, 18 teeth (16 teeth to the inch) for use with 121398.....
121169	22919	Presser Foot.....
121412	22919	Tape Reel Arm with 8879, 23263 and 120537.....
23263	22919	Tape Reel Arm Steady Pin.....
51097J	22919	" " " Thumb Screw.....
120536	22919	" " Disc with 120538 and 120539.....

From the library of: Hammond Needler

## BINDERS

No.	Plate	Name
120537	22919	Tape Reel Disc Pin.....
8879	22919	" " " " Washer (cloth)...
120538	22919	" " " Stud (wood).....
120539	22919	" " " Sleeve (brass)...
121398XC	22919	Throat Plate with 43525, for use with 121397.....
121168	22919	Binder (transverse) on Shank com- plete, for 3/4 in., 7/8 in., and 1 in. tape, Nos. 3146, 120536, 121167, 121169, 121397, 121398XC, 121412 and two 51097J.

## BINDER AND PIPING ATTACHMENT

No.	Plate	Name
120532	22920	Binder (transverse) on Shank.....
51097J	22920	" " " " Thumb Screw.....
3146	22920	Binder (transverse) on Shank Thumb Screw Washer.....
26603	22920	Feed Dog, 20 teeth (16 teeth to the inch) for use with 120741.....
120737	22920	Piping Attachment with 217J.....
217J	22920	" " Adjusting Screw...
190J	22920	" " Screw (2).....
7071	22920	" " " Washer (2)...
120738	22920	Presser Foot.....
120739	22920	Tape Guide.....
120535	22920	" Reel Arm with 23263 and 120537.
23263	22920	" " " Pin.....
51097J	22920	" " " Thumb Screw.....
120536	22920	" " Disc with 120538 and 120539 (2).....
120537	22920	Tape Reel Disc Pin.....
120538	22920	" " " Stud (wood) (2).....
120539	22920	" " " Sleeve (brass) (2).....
120775	22920	Tape Reel Pin.....
120740	22920	" " " 120775 with 42290.....
42290	22920	" " " Washer.....
120741XC	22920	Throat Plate with 43525, for use with 26603.....
43525	22920	Throat Plate Stud.....
120742	22920	Binding and Piping Attachment com- plete, Nos. 3146, 26603, 120532, 120535, 120737 to 120741XC and two each 190J, 7071, 51097J and 120536.....

## BINDERS

## BINDERS (Foot)

No.	Plate	Name
120801	22921	Binder for general work.....
120802	22921	Binder for general work.....
36700	22921	Binder (left).....
28717	22921	" (right).....
35069	22921	" for strip to turn the upper edge in, for skirt facings, etc.
28769	22921	Binder to turn top only.....

## BINDERS ON SHANK

No.	Plate	Name
25705	22922	Binder on Shank for 3/8 in. tape....
25706	22922	" " " " 7/16 in. tape...
25707	22922	" " " " 1/2 in. tape....
25708	22922	" " " " 9/16 in. tape...
25709	22922	" " " " 5/8 in. tape....
25710	22922	" " " " 11/16 in. tape..
25711	22922	" " " " 3/4 in. tape....
25712	22922	" " " " 13/16 in. tape..
25713	22922	" " " " 7/8 in. tape....
25714	22922	" " " " 15/16 in. tape..
25715	22922	" " " " 1 in. tape.....
28611	22922	Binder on Shank for suspender webs..
28631	22922	" " Shank.....
28632	22922	" " " to turn edges under.
28633	22923	" " " " top edge only for binding coats.....
28634	22923	Binder on Shank to turn top edge only for raw edge binding.....
28635	22922	Binder on Shank for 7/8 in. binding.
28637	22925	" " " for bias binding, to turn top edge only, with guide for inserting canvas strip.....
28638	22924	Binder on Shank for dress shields...
28639	22922	" " " to turn top edge only, for suspenders.....
28641	22922	Binder on Shank for 11/16 in. bind- ing.....
28643	22924	Binder on Shank with Guide (wire) for mattress work.....
28693	22922	Binder on Shank for binding the arm holes in cotton garments.....
28724	22923	Binder on Shank for binding the neck of knit underwear.....
28938	22923	Presser Foot for use with 28724.....
28732	22925	Binder on Shank to turn under both edges of binding.....
28733	22922	Binder on Shank for binding corset covers.....
28804	22923	Binder on Shank for binding dress shields.....

No.	Plate	Name
35040	22923	Presser Foot for use with 28804.....
28970	22924	Binder on Shank for bias binding, to turn both edges under.....
35065	22926	Binder on Shank for strip, to turn in upper edge only, for skirt facings, etc.....
35208	22926	Binder on Shank, to turn in both edges, for bias or straight binding, for skirts, wrappers, shirt waist, etc.....
19474	22926	Feed Dog, 14 teeth (16 teeth to the inch) for use with 19475 and 35208.....
35066	22926	Presser Foot for use with 35065 and 35208.....
7298	22926	Presser Foot Hinge Pin.....
120143	22926	" " Plate.....
19335	22926	" " Shank.....
120144	22926	Presser Foot (hinged) complete for use with 35065 and 35208, Nos. 7298, 19335 and 120143.....
19475XC	22926	Throat Plate (large needle hole) for use with 19474.....
28731	22925	Binder on Shank, to turn under both edges of binding 1/8 in.....
35226	22925	Binder on Shank, for mattress work..
35352	22924	" Folder on Shank.....
35353	22924	Binder Folder Hinge Plate.....
1425B	22924	" " " Screw.....
2749	22924	" " " Friction Washer.....
35354	22924	Binder on Shank (hinged) complete, for mattress work, Nos. 1425B, 2749, 35352 and 35353.....

### BINDERS (Horn) ON SHANK

No.	Plate	Name
28619	22927	Binder (horn) on Shank.....
28620	22927	Presser Foot for use with 28619.....
35067	22927	Binder (horn) on Shank, for strip, to turn both edges in, for ladies' collars, etc.....
35066	22927	Presser Foot for use with 35067.....
7298	22927	" " Hinge Pin.....
120143	22927	" " Plate.....
19335	22927	" " Shank.....
120144	22927	Presser Foot (hinged) complete, for use with 35067, Nos. 7298, 19335 and 120143.....
28642	22927	Binder (horn) on Shank.....
28941	22927	" " " for bias binding, to turn under both edges of binding.....

No.	Plate	Name
35062	22927	Binder (horn) on Shank, for 7/8 in. to 1 1/2 in. wide, for tape, for mattresses.....
35063	22927	Presser Foot for light work for use with 35062.....

## BOBBIN WINDERS

### BOBBIN WINDER

(SWINGING AUTOMATIC, RIGHT HAND)

FOR POWER TABLE

FOR "V" BELT

No.	Plate	Name
259428	23253	Brake (leather).....
259429	23253	" Clamp.....
200113F	23253	" " Screw.....
259430	23253	Bobbin Winder and Tension Bracket Base.....
225453	23253	Frame with 202277 and 259660.....
225454	23253	" Hinge Pin.....
202277	23253	" Oil Packing (wick).....
259660	-----	" Well Washer.....
225455	23253	" Spring.....
225456	23253	" Plunger.....
259461	23253	Pulley with 200380C.....
200380C	23253	" Set Screw.....
225381	23253	Spindle.....
225444	23253	Stop Latch.....
200056E	23253	" " Screw.....
225458	23253	" " Thumb Lever.....
225459	23253	" " " Hinge Stud...
225459	23253	" " " Joint Stud...
202478	23253	" " Trip Lever.....
200299H	23253	" " " Hinge Screw...
225461	23253	Tension Bracket with 201499B.....
200082D	23253	" " Screw.....
228026	23253	" " Washer.....
2102	23253	" Disc (2).....
13710	23253	" Spring.....
201499B	23253	" Stud.....
201572B	23253	" Thumb Nut.....
225462	23253	Tension Bracket complete, Nos. 13710, 201572B, 225461 and two 2102.....
259462	23253	Bobbin Winder complete for "V" belt, Nos. 200056E, 200082D, 200113F, 200299H, 202478, 225381, 225444, 225453 to 225456, 225458, 225462, 228026, 259428 to 259430, 259461, two each 225459 and wood screws 3/4 in. No. 12 R.H.....

**CORDERS**

WHEN ORDERING CORDERS, OR PARTS THEREOF, STATE

SIZE OR NUMBER OF CORDS TO THE INCH

**CORDER (Adjustable)**

FOR SHORT TURNS ON CUSHIONS

No.	Plate	Name
26795	24332	Cord Guide.....
26796	24332	" " Arm.....
1044D	24332	" " Hinge Screw.....
120206	24332	" " Bed with 457AL.....
457AL	24332	" " Leveling Screw.....
190J	24332	" " Screw.....
120207	24332	Corder complete, Nos. 190J, 1044D, 26795, 26796 and 120206.....
121446	24332	Feed Dog, spiked teeth, 13 teeth (10 teeth to the inch) for use with 26605.....
120208	24332	Presser Foot (grooved).....
26605XC	24332	Throat Plate, for use with 121446....

**CORDER FOR TOP CORDING**

No.	Plate	Name
25788	22929	Arm.....
190J	22929	" Adjusting Screw.....
25791	22929	" Bracket.....
25790	22929	" Hinge Pin.....
879D	22929	" Locking Screw.....
25792	22929	Arm and Bracket complete, Nos. 190J, 879D, 25788, 25790 and 25791....
12372	22929	Feed Dog, 13 teeth (12 teeth to the inch) for use with 12442.....
25984	22929	Presser Foot.....
12442XC	22929	Throat Plate, small needle hole, for use with 12372.....
26328	22929	Corder complete, Nos. 135D, 12372, 12442XC, 25792 and 25984.....
135D	22929	Corder Screw.....

**CORDER FOR TOP AND BOTTOM CORDING**

THIS CORDER IS THE SAME AS 26328 WITH THE

FOLLOWING EXCEPTIONS:

No.	Plate	Name
28629	22930	Feed Dog, 13 teeth (14 teeth to the inch) for use with 28630, in place of 12372.....
26167	22930	Presser Foot, in place of 25984.....

No.	Plate	Name
28630XC	22930	Throat Plate for use with 28629, in place of 12442.....
28788	22930	Corder complete, Nos. 135D, 25792, 26167, 28629 and 28630XC.....

**CORDER (Bow) FOR TOP CORDING**

No.	Plate	Name
26649	22929	Corder (bow) complete.....

**CORDER FOR EDGE CORDING PLUSH**

No.	Plate	Name
35026	22930	Corder on Shank.....
35027	22930	Feed Dog, 15 teeth (14 teeth to the inch) for use with 35029.....
35028	22930	Presser Foot.....
35029XC	22930	Throat Plate for use with 35027.....
35030	22930	Corder complete, Nos. 35026 to 35029XC.....

**EDGE FOLDERS**

No.	Plate	Name
28649	22929	Edge Folder on Shank.....
28709	22929	" " (double) on Shank, for canvas.....
28735	22930	Edge Folder on Shank, for seaming umbrellas.....
28767	22930	Edge Folder (double) on Shank, the under fold to extend 1/16 in. beyond edge of the upper fold...
28753	22930	Edge Folder and Guide on Shank, for top fold only.....
35175	22931	Edge Folder on Shank.....
12450	22931	Feed Dog, 11 teeth (18 teeth to the inch) for use with 12451, 12464 and 35175.....
35176	22931	Presser Foot for use with 35175.....
12464XC	-----	Throat Plate, large needle hole, for use with 12450.....
12451XC	22931	Throat Plate, small needle hole, for use with 12450.....
36292	24332	Edge Folder (double).....
28972	24332	" " Holder.....
35610	24332	" " Friction Washer..
940F	24332	" " Hinge Screw.....
28973	24332	" " Shank.....
51224W	24332	" " Thumb Screw.....

From the library of: Diamond Needle Corp

No.	Plate	Name
7071	24332	Edge Folder Thumb Screw Washer.....
36293	24332	Edge Folder (double) hinged (adjustable) complete, Nos. 940F, 7071, 28972, 28973, 35610, 36292 and 51224W.....
44252	24332	Feed Dog, 12 teeth (12 teeth to the inch) for general work for use with 36293 and 44256.....
36294	24332	Presser Foot for use with 36293.....
44256XC	24332	Throat Plate for use with 44252.....

## EDGE GUIDE (Roller)

No.	Plate	Name
26803	22933	Bed with 2362.....
220J	22933	Leveling Screw (4).....
121146	22933	Slide with 26809, 51916 and two 12152.....
121147	22933	Slide with 26809, 51917 and two 12152.....
26805	22933	Slide Cap (left).....
207F	22933	" " " Screw.....
2362	22933	" " " Steady Pin.....
26806	22933	" " (right).....
207F	22933	" " " Screw (large).....
233J	22933	" " " " (small).....
26807	22933	" Lever.....
94D	22933	" " Hinge Screw.....
51916	22933	" Roller and Screw Stud.....
51917	22933	" " Cone and Screw Stud....
26808	22933	Slide Spring.....
26809	22933	" " Cover.....
12152	22933	" " " Rivet (2).....
26810	22933	Edge Guide (roller) complete, Nos. 94D, 233J, 26803, 26805 to 26808, 121146, two 207F and four 220J.....
121148	22933	Edge Guide (cone shaped roller) complete, Nos. 94D, 233J, 26803, 26805 to 26808, 121147, two 207F and four 220J.....
190J	22933	Edge Guide Screw.....

## EDGE GUIDE (Roller)

## FOR GLOVE WORK

No.	Plate	Name
36185	22932	Arm with 1988.....
36186	22932	" Friction Washer.....
1425D	22932	" Hinge Screw.....
1988	22932	" Roller and Screw Stud.....

No.	Plate	Name
36187	22932	Bed with four 465F.....
465F	22932	" Leveling Screw (4).....
36183	22932	Edge Guide (roller) complete, Nos. 1425D and 36185 to 36187.....

## FACE PLATE THREAD LUBRICATOR

No.	Plate	Name
62819	23280	Face Plate Thread Lubricator Oil Pad (felt).....
143353	23280	Face Plate Thread Lubricator Oil Pad Holder.....
143354	-----	Face Plate Thread Lubricator Oil Pad Holder 143353 with 62819, 62827 and 143355.....
143355	23280	Face Plate Thread Lubricator Oil Pad Retainer.....
17822	23280	Face Plate Thread Lubricator Oil Reservoir Rivet.....
8068	23280	Face Plate Thread Lubricator Oil Reservoir Rivet Washer (inside).
124371	23280	Face Plate Thread Lubricator Oil Reservoir Rivet Washer (outside)
62827	23280	Face Plate Thread Lubricator Oil Wick.....
143356	23280	Face Plate Thread Lubricator complete, Nos. 8068, 17822, 124371 and 143354.....
143357	23280	Face Plate Thread Lubricator 143356 with 140050J and 143264.....
143264	23280	Face Plate Thread Lubricator Adaptor
140050J	23280	" " " " " Screw..

## FEED DOGS AND THROAT PLATES

No.	Plate	Name
26603	22951	Feed Dog, 20 teeth (16 teeth to the inch) for use with 26605.....
26605XC	22951	Throat Plate, large needle hole, for use with 26603.....
19474	24333	Feed Dog, 14 teeth (16 teeth to the inch) for use with 19475, 24572 and 36906.....
19475XC	24333	Throat Plate, large needle hole, for use with 19474.....
24572XC	-----	Throat Plate, small needle hole, for use with 19474.....
36906XC	24333	Throat Plate, with under guide, for rick rack for use with 19474....
121446	22951	Feed Dog (spiked teeth) 13 teeth (10 teeth to the inch) for use with 127306 and 127307.....

From the library of Daniel Healey Corp.



No.	Plate	Name
127306XC	22951	Throat Plate, large needle hole, for use with 121446.....
127307XC	-----	Throat Plate, small needle hole, for use with 121446.....
121444	22951	Feed Dog, 13 teeth (16 teeth to the inch) for use with 121445.....
121445XC	22951	Throat Plate for use with 121444....
121397	22951	Feed Dog, 18 teeth (16 teeth to the inch) for use with 121398.....
121398XC	22951	Throat Plate with 43525, for use with 121397.....
43525	22951	Throat Plate Stud for 121398.....
12468	22951	Feed Dog, 16 teeth (16 teeth to the inch) beveled for hemmer for shirt work for use with 139616 and 139617.....
139616XC	-----	Throat Plate, large needle hole, for use with 12468.....
139617XC	22951	Throat Plate, small needle hole, for use with 12468.....
44156	22951	Feed Dog, 24 teeth (24 teeth to the inch) for silk, for use with 19418 and 19419.....
19418XC	22951	Throat Plate, large needle hole, for use with 44156.....
19419XC	-----	Throat Plate, small needle hole, for use with 44156.....

## FINGER GUARDS

### FINGER GUARD (Metal)

No.	Plate	Name
121326	22931	Finger Guard.....
36819	22931	" " Friction Washer.....
36820	22931	" " Holder with 196J.....
196J	22931	" " " Set Screw.....
50316J	22931	" " Screw.....
121327	22931	Finger Guard (metal) complete, Nos. 36819, 36820, 50316J and 121326.

### FINGER GUARD (Wire)

No.	Plate	Name
120857	22931	Finger Guard.....
120858	22931	" " Holder with 50302J.....
50302J	22931	" " " Set Screw.....
236J	22931	" " Screw (2).....
120860	22931	Finger Guard (wire) complete, Nos. 120857, 120858 and two 236J.....

## GUIDES (Miscellaneous)

No.	Plate	Name
35190	22932	Guide.....
35866	22932	" for flush throat plate.....
25874	22932	" for raised throat plate.....
25873	22932	" (combination).....
28658	22932	" (roller) with 1852.....
1852	22932	" Roller for 28658.....
284W	22932	" Thumb Screw (long).....
732W	22932	" " " (short).....
3146	22932	" " " Washer (2).....
28971	22933	Guide.....
28972	22933	" Holder.....
35610	22933	" " Friction Washer.....
940J	22933	" " Hinge Screw.....
120427	22933	" " Shank.....
51224W	22933	" Thumb Screw.....
7071	22933	" " " Washer.....
120428	22933	Guide (adjustable, hinged) complete, Nos. 940J, 7071, 28971, 28972, 35610, 51224W and 120427.....

## HEMMERS

### HEMMER

WITH LEVER FOR OPENING THE FOLDER AND RELEASING

THE HEM, SO THAT IT CAN BE FINISHED WITHOUT

REMOVING THE HEMMER FROM MACHINE

FOR SKIRTS, OVERALLS, OR SIMILAR

### CLOSED ARTICLES

No.	Plate	Name
28679	22934	Hemmer Bed.....
233J	22934	Hemmer Folder (left) Screw.....
2362	22934	" " " Steady Pin.....
28685	22934	" " Disengaging Lever.....
94D	22934	" " " "
		Hinge Screw.....
2362	22934	Hemmer Folder Disengaging Lever Stop Pin.....
28682	22934	Hemmer Slide with 28687 and two each 2362 and 12152.....
28683	22934	Hemmer Slide Cap (left).....
28684	22934	" " " (right).....
207F	22934	" " " Screw (back) (2)...
233J	22934	" " " " (front) (2)...
28686	22934	" " Spring.....
28687	22934	" " Cover.....
12152	22934	" " " Rivet (2).....
28688	22934	Hemmer complete, Nos. 94D, 28679, 28682 to 28686, two 207F and three 233J.....

From the library of: Diamond Needle Corp.

No.	Plate	Name
190J	22934	Hemmer Screw.....
18055	22934	Presser Foot Hinge Pin.....
28689	22934	" " Plate.....
28690	22934	" " Shank.....
26231	22934	" " Spring.....
28691	22934	Presser Foot (spring hinged) complete, Nos. 18055, 26231, 28689 and 28690.....

## HEMMERS (Foot)

No.	Plate	Name
120938	22934	Hemmer (foot) for 3/32 in. hem.....
120803	22934	" " " 1/8 in. hem.....
120804	22934	" " " 5/32 in. hem.....
120805	22934	" " " 3/16 in. hem.....
36122	22935	" " " 7/32 in. hem.....
120806	22935	" " " 1/4 in. hem.....
120807	22935	" " " 5/16 in. hem.....
35710	22935	" " " 3/32 in. hem with guide on bottom to the right of needle hole.....
35682	22935	Hemmer (foot) for 1/8 in. hem with guide on bottom to the right of needle hole.....
36524	22935	Hemmer (foot) for 5/32 in. hem with guide on bottom to the right of needle hole.....
35997	22935	Hemmer (foot) for 3/16 in. hem with guide on bottom to the right of needle hole.....
36309	22935	Hemmer (foot) for 7/32 in. hem with guide on bottom to the right of needle hole.....
36072	22935	Hemmer (foot) for 1/4 in. hem with guide on bottom to the right of needle hole.....
120898	22935	Hemmer (foot) for 1/16 in. to 1/8 in. hem, for China silk, etc....
120911	22935	Hemmer (foot) for 5/32 in. to 1/4 in. hem, for China silk, etc....
36413	22935	Hemmer (foot) plain bottom, 1/16 in. hem.....
36414	22935	Hemmer (foot) plain bottom, 3/32 in. hem.....
36480	22935	Hemmer (foot) plain bottom, 5/32 in. hem.....
36416	22935	Hemmer (foot) plain bottom, 3/16 in. hem.....
120837	22935	Hemmer (foot) plain bottom, 1/8 in. hem, slotted for lace.....

## HEMMERS ON SHANK

No.	Plate	Name
12450	22936	Feed Dog, 11 teeth (18 teeth to the inch) for use with 12451, 12464 and 26655.....
26656	22936	Presser Foot for use with 26655.....
12464XC	-----	Throat Plate, large needle hole, for use with 12450.....
12451XC	22936	Throat Plate, small needle hole, for use with 12450.....
26655	22936	Hemmer on Shank for 3/32 in. hem....
26660	22936	" " " " 3/32 in. hem, for umbrella work.....
26662	22936	Hemmer on Shank (wide).....
26664	22936	" " " for raw edge silk...
26666	22936	" " " " 1/8 in. hem.....
26935	22936	" " " (narrow).....
28948	22936	" " " for one fold, with right hand lower guide, for lace
36521	22937	Hemmer on Shank for 1/4 in. hem....
36712	22937	" " " " 1/4 in. hem, for umbrella work.....
28623	22937	Hemmer and Corder on Shank, to take goods from above to cord bottom.
28624	22937	Presser Foot with groove on bottom to the right of needle hole, for use with 28623.....
28627	22940	Hemmer on Shank, for 1/8 in. to 5/8 in. gauges for Marseilles quilts
28628	22940	Presser Foot for use with 28627.....
28650	22938	Hemmer on Shank, for hemming heavy Canton flannel.....
28651	22939	Hemmer on Shank, for turning tops and bottoms of canvas leggings..
28652	22938	Hemmer on Shank, for 1 9/16 in. to 2 in. hem.....
28653	22938	Hemmer on Shank, for 2 9/16 in. to 3 in. hem.....
28700	22940	Hemmer (short head) on Shank, for hemming stable blankets.....
28701	22940	Presser Foot (tube) for laying braid on stable blankets, for use with 28700.....
36589	22940	Presser Foot for use with 28700.....
28710	22938	Hemmer on Shank, for 1/8 in. hem....
120337	22938	" " " " 1/8 in. to 3/8 in. hem, for bottom of shirt waists.....
28711	22938	Hemmer on Shank, for 1/8 in. to 1/2 in. hem, for hemming towels....
28719	22938	Hemmer on Shank, for 1/4 in. to 1/2 in. hem.....
28720	22938	Hemmer on Shank, for 3/4 in. to 1 in. hem.....
120338	22941	Hemmer for 120340.....

HEMMERS

No.	Plate	Name
120339	22941	Hemmer Shank for 120340.....
1443J	22941	" " Screw (2).....
120340	22941	Hemmer on Shank complete, for 1/2 in. to 2 in. hem, Nos. 120338, 120339 and two 1443J.....
28721	22939	Hemmer on Shank, for 1 1/4 in. to 2 in. hem.....
36776	22941	Hemmer on Shank, for 2 1/4 in. to 3 in. hem.....
28722	22939	Hemmer on Shank, for heavy woven goods.....
28723	22939	Hemmer on Shank, with guide, for hemming and stitching on lace in one operation.....
120367	22939	Hemmer on Shank, for handkerchief work.....
28736	22942	Hemmer on Shank, for umbrella work..
28737	22939	" " " soft material to turn the hem under.....
28738	22942	Hemmer on Shank, 3/8 in. hem, to turn the hem under.....
28739	22941	Hemmer on Shank, 3 in. hem, for sheets and pillow slips, to turn the hem under.....
28935	22941	Hemmer on Shank for bobbinette material, to turn the hem under...
35022	22937	Hemmer on Shank, for 1/16 in. hem, with right hand lower guide for lace.....
35475	22937	Hemmer on Shank, for 5/32 in. hem, with right hand lower guide for lace.....
35023	22937	Hemmer on Shank, for 1/16 in. hem, with left hand lower guide for lace.....
120452	22939	Hemmer on Shank, for 1/32 in. to 1/8 in. hem, for Windsor ties.....
35064	22941	Hemmer on Shank, for 1 in. to 2 in. hem, for general work.....
35104	22939	Hemmer on Shank, for bottom of shirt waists, for inserting drawing or shirring string.....
35063	22939	Presser Foot, for light work, for use with 35104.....
35832	22939	Presser Foot, for heavy work, for use with 35104.....
35166	22942	Hemmer on Shank, for 1 in. hem, to turn the goods under.....
28614	22942	Presser Foot for use with 35166.....
120289	22942	Hemmer on Shank, for 2 in. hem, to turn the goods under.....
19474	22942	Feed Dog, 14 teeth (16 teeth to the inch) for use with 19475 and 35236.....
35063	22942	Presser Foot for light work for use with 35236.....

HEMMERS

No.	Plate	Name
19475X	22942	Throat Plate, large needle hole, for use with 19474.....
35236	22942	Hemmer on Shank, for 7/16 in. hem...
19474	22943	Feed Dog, 14 teeth (16 teeth to the inch) for use with 19475 and 35241.....
35066	22943	Presser Foot for use with 35241.....
7298	22943	" " Hinge Pin.....
120143	22943	" " Plate.....
19335	22943	" " Shank.....
120144	22943	Presser Foot (hinged) complete, for use with 35241, Nos. 7298, 19335 and 120143.....
19475X	22943	Throat Plate, large needle hole, for use with 19474.....
35241	22943	Hemmer on Shank, for Canton flannel etc.....
26603	22943	Feed Dog, 20 teeth (16 teeth to the inch) for use with 26605, 35681 and 35863.....
35066	22943	Presser Foot for use with 35681 and 35863.....
26605X	22943	Throat Plate, large needle hole, for use with 26603.....
35863	22943	Hemmer on Shank, for canvas work....
35679	22940	" Folder on Shank for 35681....
35353	22940	" " Hinge Plate for 35681.
1425B	22940	" " " Screw for 35681.
36006	22940	" " " " Washer for 35681.....
35681	22940	Hemmer on Shank (hinged) complete, for mattress work, Nos. 1425B, 35353, 35679 and 36006.....

HEMSTITCHER

No.	Plate	Name
28671	22934	Hemstitcher.....

KNEE LIFTERS

KNEE LIFTER

FOR POWER TABLE

No.	Plate	Name
144810	24330	Bell Crank.....
144811	24330	" " Bracket.....
158F	24330	" " " Screw (2).....
143104	24330	" " Hinge Pin.....
144812	----	Bell Crank complete, Nos. 143104, 144810 and 144811.....
143242	24330	Lifting Lever with 448AL.....

From the Library of the High Speed Needle Corp.

No.	Plate	Name
143108	24330	Lifting Lever Connecting Rod.....
1611J	24330	" " " " Nut....
1611J	24330	" " " " " "
		Lock Nut.....
143109	24330	Lifting Lever Connecting Rod Swivel.
802D	24330	" " Hinge Screw.....
12241	24329	" " Link.....
766E	24329	" " " Hinge Screw.....
12240	24330	" " Pin.....
448AL	24330	" " " Set Screw.....
23273	24330	" " Spring.....
2763	22338	Rock Shaft.....
139633	-----	" " 2763 with 2770, 6337 and 139623.....
127312	22338	Rock Shaft Hanger (back) with two wood screws 1 in. No. 10 F.H....
12242	22338	Rock Shaft Hanger (front) with two wood screws 1 in. No. 10 F.H....
2765	22338	Rock Shaft Knee Arm.....
2766	22338	" " " " Hub with 356C...
356C	22338	" " " " " Set Screw...
2768	-----	Rock Shaft Knee Arm complete, Nos. 2765 to 2767.....
2767	22338	Rock Shaft Knee Arm Plate with 356C.
356C	22338	" " " " " Set Screw.
6337	22338	" " Lifting Bracket with two 356C.....
139623	22338	Rock Shaft Lifting Bracket Hook....
356C	22338	" " " " " Set Screw.....
356C	22338	Rock Shaft Lifting Bracket Set Screw
2770	22338	" " Stop Dog with 140219C....
140219C	22338	" " " " " Set Screw.....
139624	22338	Rock Shaft complete, Nos. 2768, 12242, 127312 and 139633.....
144813	-----	Knee Lifter complete, Nos. 766E, 802D, 12240, 12241, 23273, 139624, 143108, 143109, 143242, 144812 and two each 158R and 1611J.....

**KNEE LIFTER**

FOR FOOT POWER AND INDIVIDUAL

**MOTOR STAND**

No.	Plate	Name
144810	24330	Bell Crank.....
144811	24330	" " Bracket.....
158R	24330	" " " Screw (2).....
143104	24330	" " Hinge Pin.....
144812	-----	Bell Crank complete, Nos. 143104, 144810 and 144811.....
143242	24330	Lifting Lever with 448AL.....
143108	24330	" " Connecting Rod.....

No.	Plate	Name
1611J	24330	Lifting Lever Connecting Rod Nut....
1611J	24330	" " " " " "
		Lock Nut.....
143109	24330	Lifting Lever Connecting Rod Swivel.
802D	24330	" " Hinge Screw.....
12241	24329	" " Link.....
766E	24329	" " " Hinge Screw.....
12240	24330	" " Pin.....
448AL	24330	" " " Set Screw.....
23273	24330	" " Spring.....
2763	22338	Rock Shaft.....
139633	-----	" " 2763 with 2770, 6337 and 139623.....
7539	22338	Rock Shaft Hanger with two wood screws 1 in. No. 10 F.H. (2)....
2765	22338	Rock Shaft Knee Arm.....
2766	22338	" " " " Hub with 356C...
356C	22338	" " " " " Set Screw...
2768	-----	Rock Shaft Knee Arm complete, Nos. 2765 to 2767.....
2767	22338	Rock Shaft Knee Plate with 356C....
356C	22338	" " " " " Set Screw.....
6337	22338	" " Lifting Bracket with two 356C.....
139623	22338	Rock Shaft Lifting Bracket Hook....
356C	22338	" " " " " Set Screw.....
356C	22338	Rock Shaft Lifting Bracket Set Screw
2770	22338	" " Stop Dog with 140219C....
140219C	22338	" " " " " Set Screw.....
139625	22338	Rock Shaft complete, Nos. 2768, 139633 and two 7539.....
144814	-----	Knee Lifter complete, Nos. 766E, 802D, 12240, 12241, 23273, 139625, 143108, 143109, 143242, 144812 and two each 158R and 1611J.....

**LAP SEAM FELLER**

No.	Plate	Name
28673	22934	Lap Seam Feller (right hand) on Shank, to fold top only.....
28674	22934	Lap Seam Guide on Shank.....

**MACHINE BASE**

No.	Plate	Name
19219	22309	Bed Frame Cushion (leather) (4)....
158C	22309	" " " Screw (8).....
19220	22309	" " " Spring (4).....

Foot Power and Individual

No.	Plate	Name
19226	22309	Bed Frame Hinge Connection (2).....
19398	-----	" " " " " 19226
		with 211E and 19397 (2).....
19397	22309	Bed Frame Hinge Connection Cap (2)..
211E	22309	" " " " " Screw
		(2).....
16555	22309	Bed Frame Hinge Plate (2).....
14010	22309	" " " " Rivet (6).....
20067	22309	" " with two each 16555,
		19398, four each 19219, 19220,
		six each 14010, wood screws
		1 1/4 in. No. 12 and eight 158C.

## PIPING ATTACHMENT

(FOR PIPING HOUSE DRESSES)

No.	Plate	Name
35245	22944	Piping Attachment on Shank with
		1443J and 120977.....
120977	22944	Piping Attachment for 35245.....
1443J	22944	" " Adjusting Screw...
44253	22944	Feed Dog, 16 teeth (16 teeth to the
		inch) for use with 44256.....
35246	22944	Presser Foot for use with 35245.....
44256XC	22944	Throat Plate for use with 44253.....

## PRESSER FEET

No.	Plate	Name
120828	22945	Presser Foot (single toe) for
		gathering.....
26638	22945	Presser Foot (double toe) for
		gathering.....
26642	22945	Presser Foot.....
26643	22945	" " Guide.....
26644	22945	" " Hinge Pin.....
26645	22945	" " Spring.....
337D	22945	" " " " Screw.....
26646	22945	Presser Foot (spring guide) com-
		plete, Nos. 337D and 26642 to
		26645.....
26650	22945	Presser Foot, for braiding.....
26801	22944	" " Adjustable Guide for
		26802 (2).....
725D	22944	Presser Foot, Adjustable Guide Screw
		(2).....
26802	22944	Presser Foot, with two adjustable
		guides, Nos. two each 725D and
		26801.....
26936	22944	Presser Foot, for etching.....

No.	Plate	Name
26978	22945	Presser Foot Graduated Adjustable
		Guide for 26977.....
335D	22945	Presser Foot Graduated Adjustable
		Guide Screw.....
26977	22945	Presser Foot with Graduated Adjust-
		able Guide with 335D and 26978,
		for tailor work.....
28672	22944	Presser Foot two grooves to the
		right of needle hole, for cord-
		ing.....
28725	22945	Presser Foot Spring Guide.....
665J	22945	" " " " Screw.....
28726	22945	" " (right hand spring
		guide) with 665J and 28725, for
		1/32 in. to 1/4 in. stitching
		margin.....

Note: When ordering Nos. 28725 or 28726, state required distance from edge of goods to seam.

28743	22945	Presser Foot (grooved) with tube,
		for cording.....
28746	22945	Presser Foot (tube) for guiding and
		stitching the left hand edge of
		ribbon.....
28908	22945	Presser Foot Spring Guide for 28909.
665J	22945	" " " " Screw.....
28909	22945	" " (left hand spring
		guide) with 665J and 28908.....
28920	22945	Presser Foot for braiding, to stitch
		braid on right hand edge.....
62527	22945	Presser Foot Hinge Pin.....
24488	22945	" " Plate.....
19223	22945	" " Shank.....
24489	22945	Presser Foot (hinged) complete, for
		heavy work, Nos. 19223, 24488
		and 62527.....
35172	22945	Presser Foot (tube) for guiding and
		stitching the right hand edge of
		ribbon.....
44158	22944	Feed Dog, 15 teeth (14 teeth to the
		inch) for use with 44161 and
		44162.....
26276	22944	Presser Foot Hinge Pin.....
44159	22944	" " Plate.....
44160	22944	" " Shank.....
44161	22944	Presser Foot (hinged) complete, Nos.
		26276, 44159 and 44160.....
44162XC	22944	Throat Plate for use with 44158.....
36022	22945	Presser Foot with 665J and 36023,
		for blind stitch cording, for 12
		to 40 ligne cord, for ornamental
		cording on skirts, suits, etc....
36023	22945	Presser Foot Cord Guide for 36022....

Note: When ordering Nos. 36022 or 36023, state the size or send sample of cord for which it is to be used.

PRESSER FEET

No.	Plate	Name
665J	22945	Presser Foot Cord Guide Screw.....
36182	22945	" " with 665J and 36183, for blind stitch braiding, for scoutache braid.....
36183	22945	Presser Foot Braid Guide.....
Note: When ordering Nos. 36182 or 36183, send sample of braid for which it is to be used		
665J	22945	Presser Foot Braid Guide Screw.....
36622	22945	" " for 36623.....
36623	22945	" " 36622 with 36576 and two 50202D.....
36576	22945	Presser Foot Finger Guard.....
50202D	22945	" " " " Screw (2).
139618	22945	" " with 228J, needle hole on left hand side.....
139619	22945	Presser Foot Strip Gauge for 139618.
228J	22945	" " " " Screw.....

PRESSER FEET WITH GRADUATED  
ADJUSTABLE GUIDES

No.	Plate	Name
28949	22946	Presser Foot.....
28950	22946	" " Graduated Adjustable Guide.....
28951	22946	Presser Foot Graduated Adjustable Guide Clamping Lever.....
2653	22946	Presser Foot Graduated Adjustable Guide Clamping Lever Hinge Pin..
28952	22946	Presser Foot Graduated Adjustable Guide Clamping Lever Spring.....
26092	22946	Presser Foot Graduated Adjustable Guide Clamping Lever Spring Rivet.....
28953	22946	Presser Foot with Graduated Adjust- able Guide complete, for tailor work, Nos. 2653, 26092 and 28949 to 28952.....
35134	22946	Presser Foot with 36696.....
35002	22946	" " Extension.....
35003	22946	" " Graduated Adjustable Guide (long, left).....
35004	22946	Presser Foot Graduated Adjustable Guide (long, right).....
35005	22946	Presser Foot Graduated Adjustable Guide (short, right).....
35006	22946	Presser Foot Graduated Adjustable Guide (short, right) flush.....
35135	22946	Presser Foot Graduated Adjustable Guide Clamp.....
35136	22946	Presser Foot Graduated Adjustable Guide Clamp Lever.....

PRESSER FEET

No.	Plate	Name
337B	22946	Presser Foot Graduated Adjustable Guide Clamp Screw.....
36696	22946	Presser Foot Graduated Adjustable Guide Clamp Steady Pin.....
35137	22946	Presser Foot with Extension and Graduated Adjustable Guides, complete, Nos. 337B, 35002 to 35006 and 35134 to 35136.....

PRESSER FOOT AND EXTENSIONS

No.	Plate	Name
139618	22945	Presser Foot with 228J (needle hole on left hand side).....
12435	22947	Presser Foot with 228J (needle hole on right hand side).....
62527	22947	Presser Foot Hinge Pin.....
20155	22947	" " Plate.....
20156	22947	" " Shank.....
20157	22947	Presser Foot (hinged) complete, Nos. 228J, 20155, 20156 and 62527....
26279	22947	Presser Foot Extension, 1/16 in. for use with 12435 and 20157....
26280	22947	Presser Foot Extension, 1/8 in. for use with 12435 and 20157....
26281	22947	Presser Foot Extension, 1/4 in. for use with 12435 and 20157....
26282	22947	Presser Foot Extension, 3/8 in. for use with 12435 and 20157....
26283	22947	Presser Foot Extension, 1/2 in. for use with 12435 and 20157....
228J	22947	Presser Foot Extension, Screw.....

QUILTERS

No.	Plate	Name
28659	22946	Quilter Guide for 28660.....
25992	22946	" " Holder with two 207F, for 28660.....
207F	22946	Quilter Guide Holder Set Screw.....
207F	22946	" " Set Screw.....
28660	22946	Quilter complete, Nos. 25992 and 28659.....
120479	22946	Quilter Guide (left).....
120480	22946	" " (right).....
120481	22946	" " Bracket.....
209AL	22946	" " " Set Screw.....
120482	-----	" " " 120481 with 120483 and two 209AL.....
120483	22946	Quilter Guide Disengaging Sleeve....
120484	22946	" " " " Spring.....

From the Library of Diana and Needle Co.

## QUILTERS

No.	Plate	Name
602D	22946	Quilter Guide Disengaging Sleeve
		Spring Screw.....
209AL	22946	Quilter Guide Set Screw.....
120485	22946	Quilter complete, Nos. 602D, 120479, 120480, 120482 and 120484.....

## RUFFLER

No.	Plate	Name
121116	22948	Driving Lever.....
51371K	22948	" " Adjusting Thumb Screw (lower).....
560B	22948	Driving Lever Adjusting Thumb Screw (upper).....
120812	22948	Driving Lever Bushing.....
120813	22948	" " Friction Washer.....
51219F	22948	" " Hinge Screw.....
1700J	22948	" " " " Nut.....
121117	22948	Frame.....
36637	22948	" Spring Plate.....
36638	22948	Ribbon Guide.....
240B	22948	" " Screw.....
121118	22948	Ruffling Blade.....
121119	22948	" " Holder.....
121120	-----	" " " 121119 with 121118 and two 120829.....
36641	22948	Ruffling Blade Holder Guide.....
36642	22948	" " " " Rivet...
51221F	22948	" " " " Hinge Screw...
1772J	22948	" " " " " "
		Nut.....
121121	22948	Ruffling Blade Lever with 560B and 51371K.....
120829	22948	Ruffling Blade Rivet (2).....
36644	22948	Separating Blade.....
120830	22948	" " Holder.....
121501	-----	" " " 120830 with 36644 and two 120829.....
36646	22948	Separating Blade Holder Friction Spring.....
36647	22948	Separating Blade Holder Hinge Stud..
36648	22948	" " " " Stop Stud...
120829	22948	" " Rivet (2).....
36644	22948	Shirring Blade.....
120818	22948	" " Holder.....
120819	22948	" " " 120818 with 36644 and two 120829.....
120829	22948	Shirring Blade Rivet (2).....
121123	22948	Ruffler complete, Nos. 240B, 1700J, 1772J, 36637, 36638, 36641, 36642, 36646 to 36648, 51219F, 51221F, 120812, 120813, 121116, 121117, 121120, 121121 and 121501.....

## RUFFLER

No.	Plate	Name
121697	22948	Ruffler 121123 with 120819 and 121696.....
121636	22948	Needle Clamp with 140204F.....
140204F	22948	" " Screw.....

## SEAMER

No.	Plate	Name
26658	22944	Seamer.....

## THREAD STABILIZER

No.	Plate	Name
143227	23280	Thread Stabilizer.....

## THREAD UNWINDER

## FOR TWO SPOOLS OR TWO LARGE CONES OF THREAD

No.	Plate	Name
225257	23289	Spool Rest with 201018C.....
150203	23289	" " Cushion (felt) (2).....
225388	23289	" " Rod.....
200383C	23289	" " " Set Screw.....
201018C	23289	" " Set Screw.....
259658	23289	" Stand with 200383C.....
225391	23289	Thread Guide (2).....
201696J	23289	" " Lock Nut.....
225326	23289	" " Position Cup.....
225324	23289	" " Rod with 208AL and 225322.....
208AL	23289	Thread Guide Rod Screw.....
225322	23289	" " " Washer.....
225258	23289	Thread Unwinder complete, Nos. 201696J, 225257, 225324, 225326, 225388, 259658, two each 150203, 225391 and three wood screws 7/8 in. No. 12 F.H.....
27739	23289	Thread Cone (wood) for large cones..
225390	23289	" " Holder, for inverted cones.....

Note: Nos. 27739 and 225390 are used with, but  
not included in 225258.....

### TUBULAR TRIMMING ATTACHMENT

(FOR MAKING 3/32 IN. TO 3/16 IN. TRIMMINGS)

No.	Plate	Name
52031	22947	Feed Dog, 19 teeth (22 teeth to the inch) for use with 52033.....
120824	22947	Strip Wire.....
35018	22947	Tape Delivery Blade.....
52033XC	22947	Throat Plate for use with 52031.....
120835	22947	Tubular Trimming Attachment.....
120836	22947	Tubular Trimming Attachment complete, Nos. 35018, 120824 and 120835...

### TUCKERS

#### TUCKER

No.	Plate	Name
36655	22948	Driving Lever.....
36656	22948	" " Hinge Stud.....
36657	22948	" " Lock Spring.....
36658	22948	" " " Rivet (2).....
120500	22948	Frame.....
26718	22948	Needle Clamp Body.....
1943	22948	" " Roller.....
1115F	22948	" " Screw.....
26719	22948	Needle Clamp complete, Nos. 1115F, 1943 and 26718.....
36660	22948	Tuck Guide.....
50238B	22948	" " Thumb Screw.....
36661	22948	" " " Washer.....
36662	22948	" Marker (lower).....
36663	-----	" " " 36662 with 36664 and two 36648.....
36664	22948	Tuck Marker (upper).....
120572	22948	" " Clamping Plate.....
50238B	22948	" " " Thumb Screw.....
36648	22948	Tuck Marker Rivet (2).....
36667	22948	" Smoothing Spring.....
86354	22948	" " Rivet (2).....
36561	22948	Tucker complete, Nos. 26719, 36655 to 36657, 36660, 36661, 36663, 36667, 120500, 120572 and two each 36658, 50238B and 86354....

#### TUCKER (Power)

No.	Plate	Name
26099	22949	Bed.....
26100	22949	Cloth Guide.....
291D	22949	" " Thumb Screw.....

No.	Plate	Name
26101	22949	Cloth Guide Slide with 26102 and two 26092.....
4604	22949	Cloth Guide Slide Rivet.....
401E	22949	" " " Screw.....
26378	22949	Leveling Plate.....
12143	22949	Presser Foot.....
26368	22949	Tuck Marking Bar.....
26369	-----	Tuck Marking Bar complete, Nos. 26368 and 26370 to 26372.....
26105	22949	Tuck Marking Bar Bracket.....
26106	22949	" " " " Hinge Pin..
220J	22949	" " " " " " " Set Screw.....
26107	22949	Tuck Marking Bar Lifting Spring.....
26108	22949	" " " Pressure Spring....
26109	22949	" " " " " " " Clamp with 196F.....
196F	22949	Tuck Marking Bar Pressure Spring Clamp Set Screw.....
334D	22949	Tuck Marking Bar Set Screw.....
26370	22949	" " Pin.....
26371	22949	" " " Guide Pin.....
26372	22949	" " " Spring.....
26102	22949	" " Plate.....
26092	22949	" " " Rivet (2).....
26111	22949	" Smoothing Spring.....
4604	22949	" " " Rivet (2).....
26377	22949	Tucker complete, Nos. 220J, 291D, 334D, 401E, 12143, 26099 to 26101, 26105 to 26109, 26111, 26369, 26378 and three 4604....
176D	22949	Tucker Screw.....

#### TUCKER

#### (LONG ARM)

No.	Plate	Name
35528	23260	Presser Foot (short plate) for 36395
36387	23260	Space Guide.....
35510	23260	" " Base with 35512, 35514 and two 1426E.....
402D	23260	Space Guide Base Screw (2).....
35511	23260	" " Indicator.....
35512	23260	" " Pin.....
35513	23260	" " Stop (left).....
35514	23260	" " " Guide Pin...
1426E	23260	" " " Screw Stud..
1657D	23260	" " " Thumb Nut...
17718	23260	" " " " " " Washer.....
35515	23260	Space Guide Stop (right).....
1426E	23260	" " " Screw Stud.
1657D	23260	" " " Thumb Nut..
17718	23260	" " " " " " Washer.....

From the library of the Copyright Clearance Center



No.	Plate	Name
50053W	23260	Space Guide Thumb Screw.....
36388	23260	Space Guide complete, Nos. 35510, 35511, 35513, 35515, 36387, 50053W and two each 1657D and 17718.....
35517	23260	Tuck Guide Arm.....
1177J	23260	" " " Screw (2).....
35518	23260	" " Base.....
50134E	23260	" " " Screw Stud.....
36389	23260	" " Bracket.....
307C	23260	" " " Screw Center (2).
56814	-----	" " " " " 307C with 1513J (2).....
1513J	23260	Tuck Guide Bracket Screw Center Nut (2).....
36390	23260	Tuck Guide Bracket Spring.....
36391	23260	" " " " Plate.....
9D	23260	" " " " Screw.....
423AL	23260	" " " Stop Screw.....
1520J	23260	" " " " " Nut...
36392	23260	" " Frame.....
36393	23260	" " " Spring.....
1510E	23260	" " " " Nut.....
35524	23260	" " " " Washer.....
803C	23260	" " " Stop Screw.....
1520J	23260	" " " " " Nut.....
35511	23260	" " Indicator.....
35525	23260	" " " Plate.....
1115F	23260	" " Screw (2).....
36394	23260	Tuck Guide complete, Nos. 9D, 423AL, 803C, 1510E, 35511, 35517, 35518, 35524, 35525, 36389 to 36393, 50134E, two each 1115F, 1177J, 1520J, 56814 and three wood screws 1 1/4 in. No. 10....
36395	23260	Tucker (long arm) complete, Nos. 35528, 36388, 36394 and two 402D

FITTINGS

FOR GENERAL WORK

No.	Plate	Name
44252	22952	Feed Dog, 12 teeth (12 teeth to the inch) for use with 44256.....
20458	22952	Presser Foot (solid).....
44256XC	22952	Throat Plate for 44252.....

Note: Above Parts are shipped with machines un-  
less otherwise specified on order.

FOR CHIFFON

No.	Plate	Name
20348	22952	Feed Dog, 22 teeth (36 teeth to the inch) for use with 12451 and 12464.....
12260	22952	Presser Foot.....
12464XC	-----	Throat Plate, large needle hole, for use with 20348.....
12451XC	22952	Throat Plate, small needle hole, for use with 20348.....

FOR FINISHING KNIT UNDERWEAR

No.	Plate	Name
20018	22952	Feed Dog, 17 teeth (15 teeth to the inch) for use with 20019.....
20020	22952	Presser Foot.....
20019XC	22952	Throat Plate, large needle hole, for use with 20018.....

FOR GENERAL MUSLIN WORK

No.	Plate	Name
20352	22952	Feed Dog, 15 teeth (16 teeth to the inch) for use with 20353 and 20354.....
12142	22952	Presser Foot.....
20353XC	-----	Throat Plate, large needle hole, for use with 20352.....
20354XC	22952	Throat Plate, small needle hole, for use with 20352.....

FOR HEAVY WORK ON DUCK, OVERALLS, ETC.

No.	Plate	Name
20119	24333	Feed Dog, 18 teeth (16 teeth to the inch) for use with 20120 and 20187.....
12259	24333	Presser Foot (solid).....
62527	24333	" " Hinge Pin.....
62925	24333	" " Plate.....
62926	24333	" " Shank.....
26231	24333	" " Spring.....
62927	24333	Presser Foot (spring hinged) com- plete, Nos. 26231, 62527, 62925 and 62926.....
20120XC	24333	Throat Plate, large oblong needle hole, for use with 20119.....

From the library of: Diamond Needle Corp

No.	Plate	Name
20187XC	-----	Throat Plate, small oblong needle hole, for use with 20119.....

## FOR TAILOR WORK

No.	Plate	Name
44136	24333	Feed Dog, 15 teeth (16 teeth to the inch) for use with 44137 and 44138.....
20458	24333	Presser Foot (solid).....
7298	24333	" " Hinge Pin.....
19334	24333	" " Plate.....
19335	24333	" " Shank.....
19336	24333	Presser Foot (hinged) complete, Nos. 7298, 19334 and 19335.....
44137XC	24333	Throat Plate, large needle hole, for use with 44136.....
44138XC	-----	Throat Plate, small needle hole, for use with 44136.....

## FOR UMBRELLA WORK

No.	Plate	Name
20275	24333	Feed Dog, 13 teeth (18 teeth to the inch) for use with 20277 and 20362.....
20276	24333	Presser Foot.....
20277XC	24333	Throat Plate, large needle hole, for use with 20275.....
20362XC	-----	Throat Plate, small needle hole, for use with 20275.....

## FOR SHIRT WORK USING A HEMMER

No.	Plate	Name
12455	22953	Feed Dog, 13 teeth (14 teeth to the inch) beveled for hemmer, for use with 12456 and 20398.....
20336	22953	Feed Dog, 16 teeth (16 teeth to the inch) beveled for hemmer, for use with 20337 and 20338.....
12468	22953	Feed Dog, 16 teeth (16 teeth to the inch) beveled for hemmer, for use with 139616 and 139617.....
20471	22953	Feed Dog, 22 teeth (22 teeth to the inch) beveled for hemmer, for use with 139616 and 139617.....
12144	22953	Presser Foot.....

No.	Plate	Name
20398XC	-----	Throat Plate, large needle hole, for use with 12455.....
12456XC	22953	Throat Plate, small needle hole, for use with 12455.....
20337XC	22953	Throat Plate, large needle hole, for use with 20336.....
20338XC	-----	Throat Plate, small needle hole, for use with 20336.....
139616XC	-----	Throat Plate, large needle hole, for use with 12468 and 20471.....
139617XC	22953	Throat Plate, small needle hole, for use with 12468 and 20471.....

## FOR SILK

No.	Plate	Name
44156	22951	Feed Dog, 24 teeth (24 teeth to the inch) for use with 19418 and 19419.....
7298	24333	Presser Foot Hinge Pin.....
19334	24333	" " Plate.....
19335	24333	" " Shank.....
19336	24333	Presser Foot (hinged) complete, Nos. 7298, 19334 and 19335.....
19418XC	22951	Throat Plate, large needle hole, for use with 44156.....
19419XC	-----	Throat Plate, small needle hole, for use with 44156.....

Genuine "SINGER" Needles should be used in "SINGER" Machines. These Needles and their Containers are marked with the Company's Trade Mark "SIMANCO" 1

Needles in Containers marked "FOR SINGER MACHINES" are NOT "SINGER" made needles. 2

Genuine "SINGER" Needles should be used  
in "SINGER" Machines.  
These Needles and their Containers  
are marked with the  
Company's Trade Mark "SIMANCO" 1

Needles in Containers marked  
"FOR SINGER MACHINES"  
are NOT "SINGER" made needles. 2

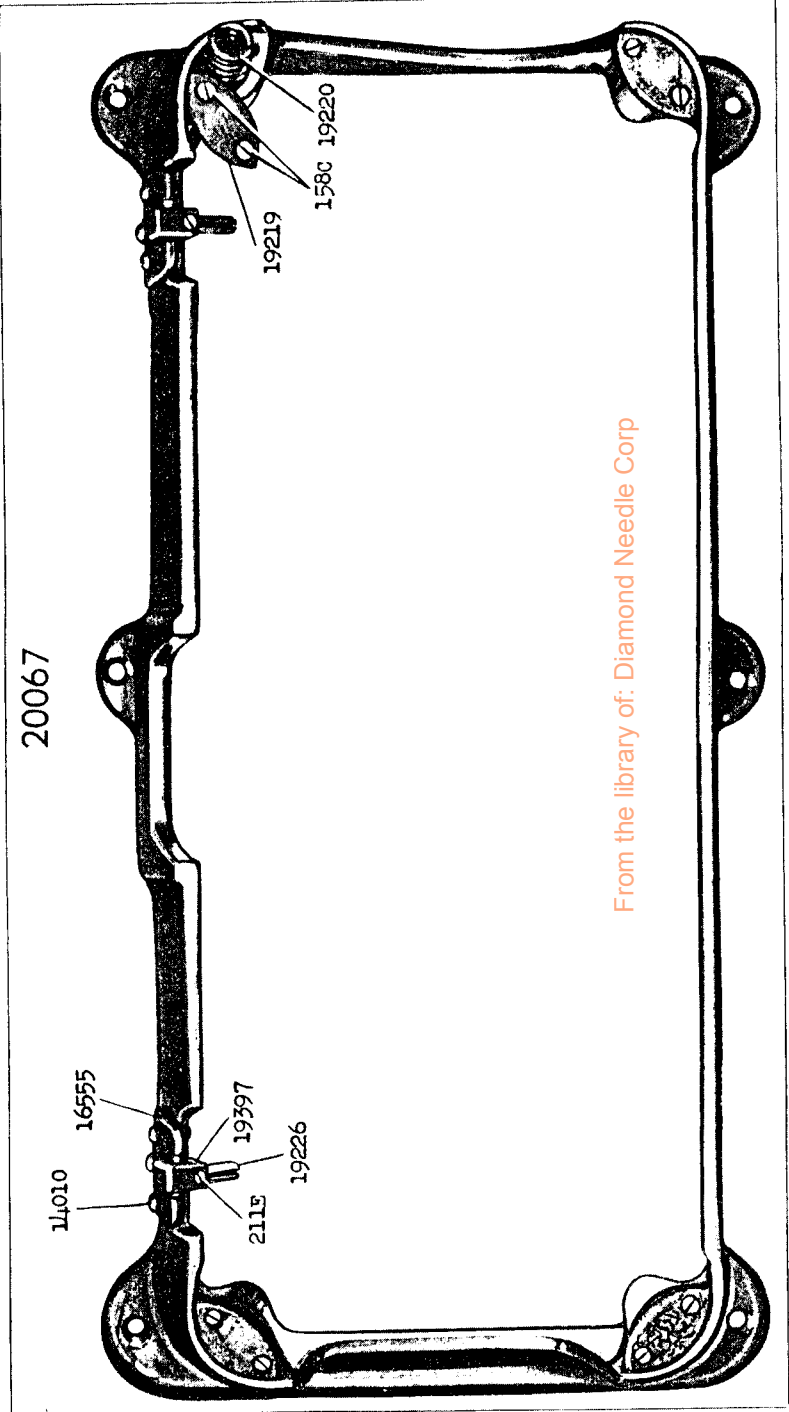

From the library of: Diamond Needle Corp

22338 - 1/3

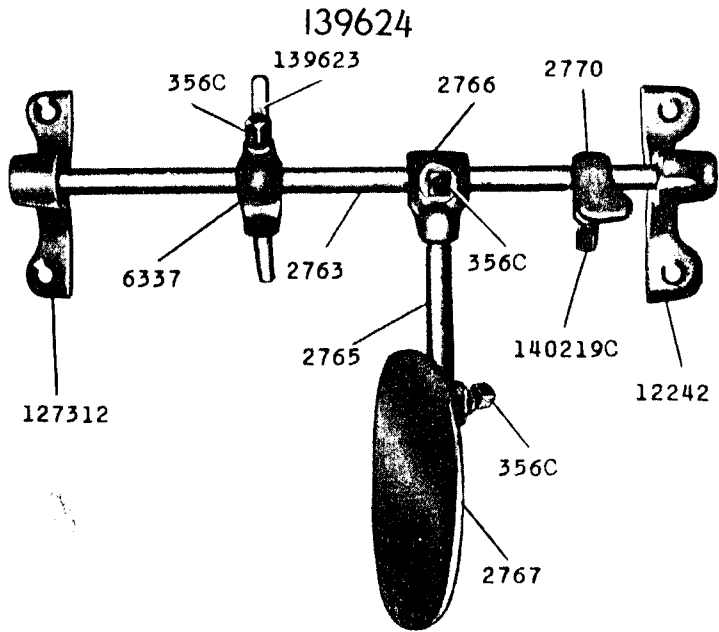

139625

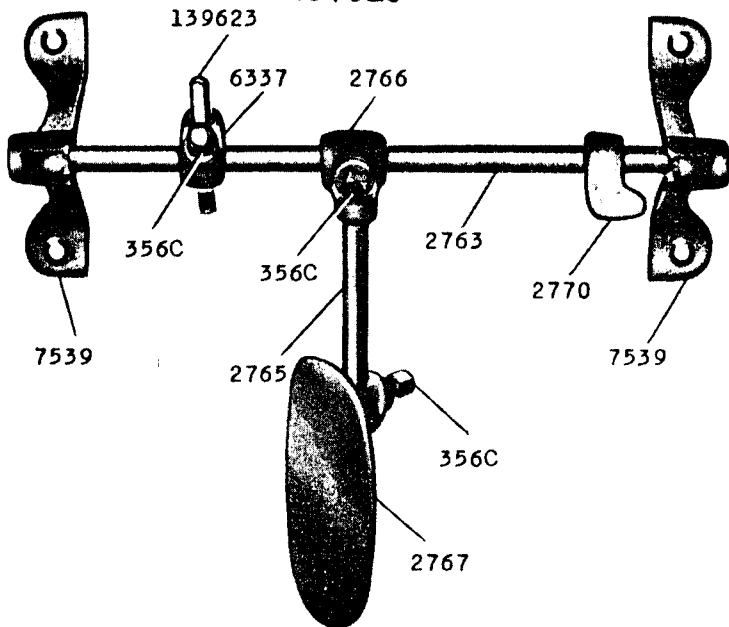

22912 - 2/3

25650

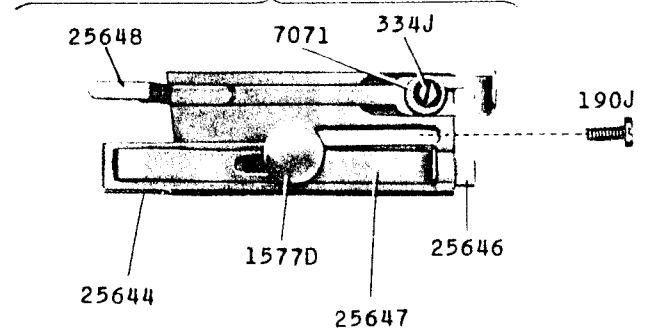

25653

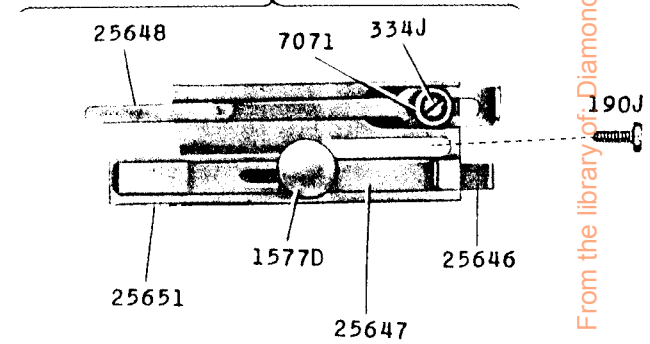

25656

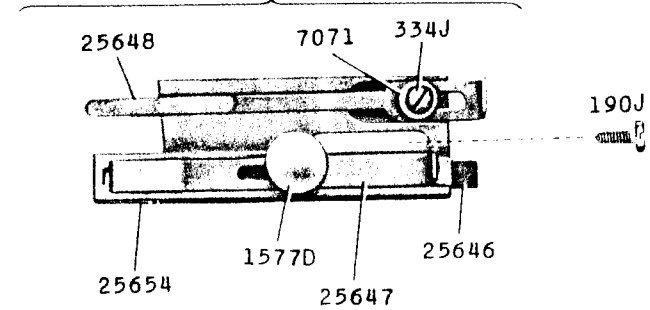

From the library of Diamond Needle Corp

22913 - 2/3

120166

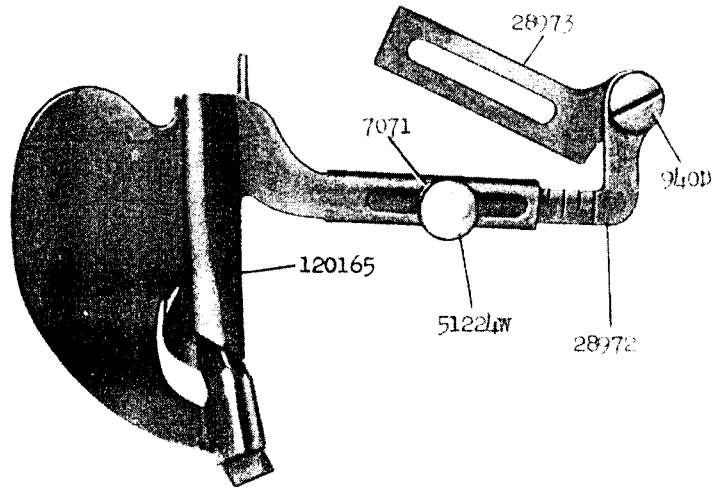

28713

36463

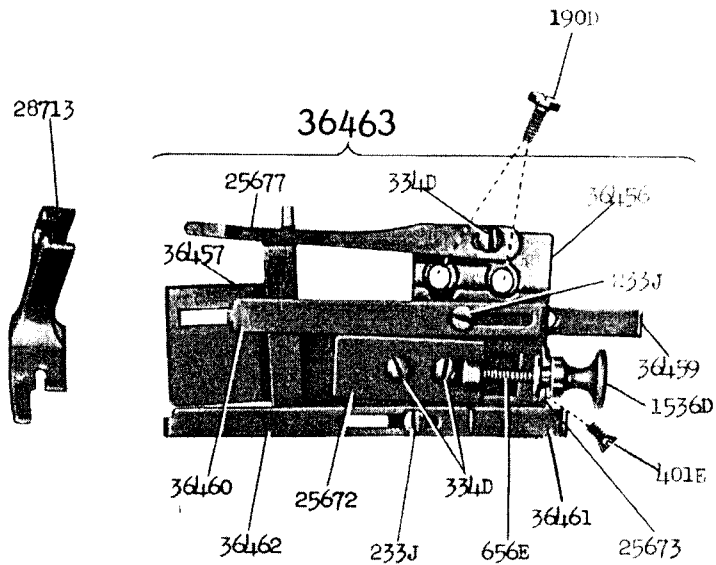

120955



22914 - 2/3

26250

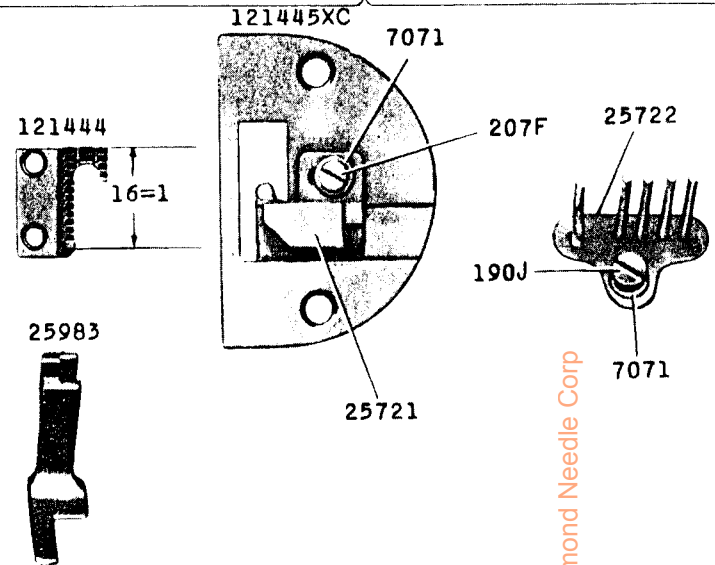

26466

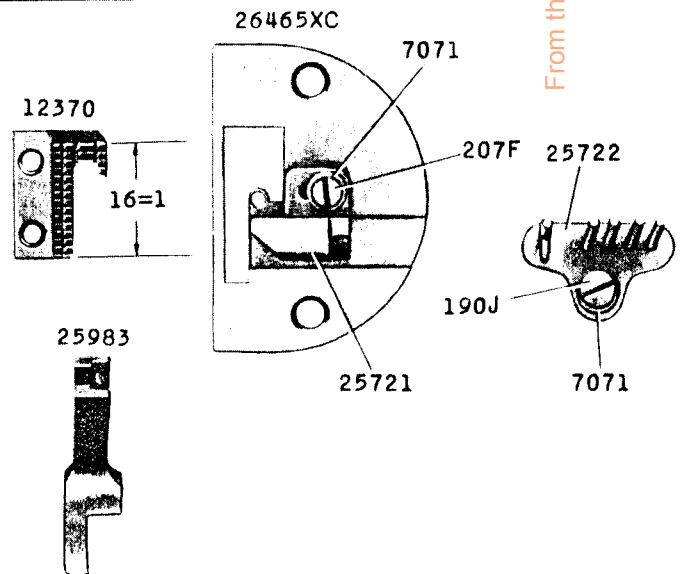

From the library of: Diamond Needle Corp

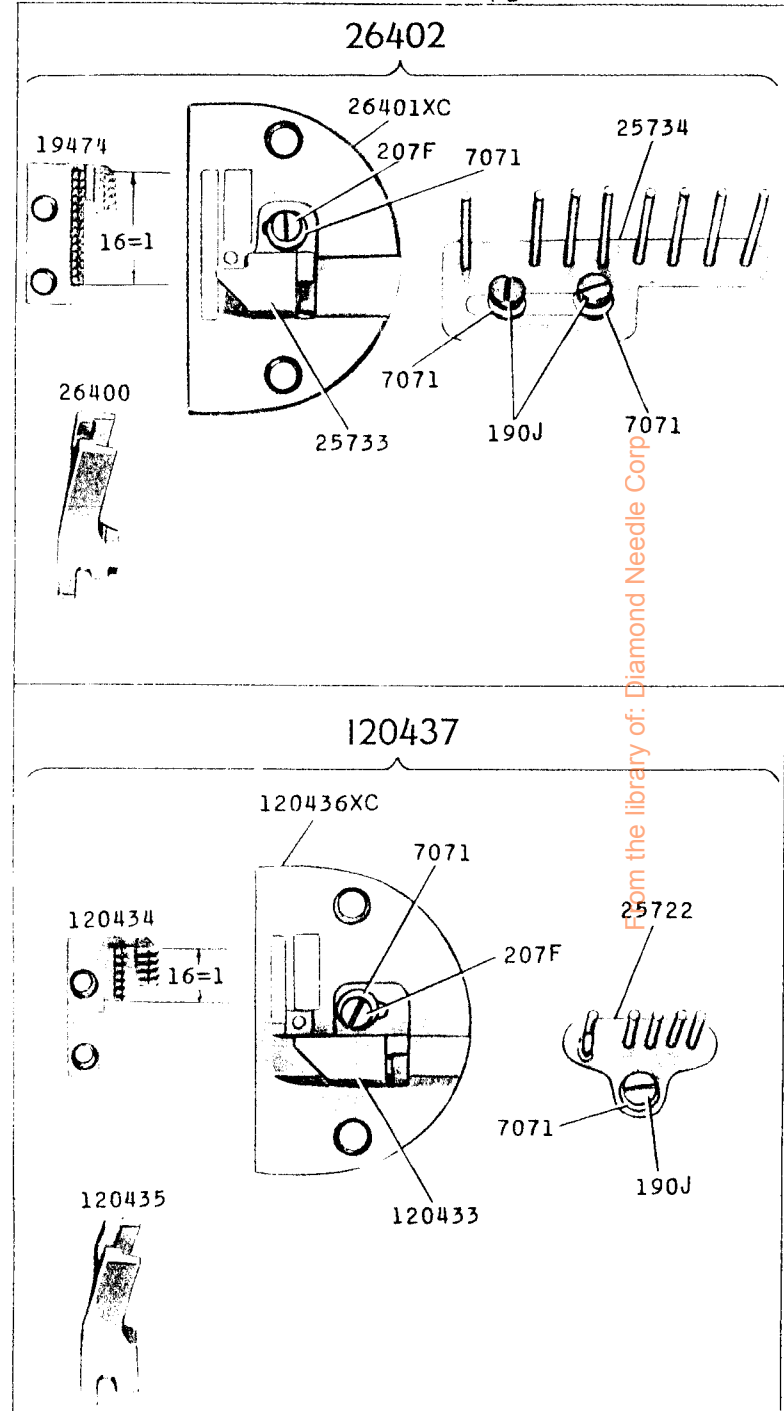
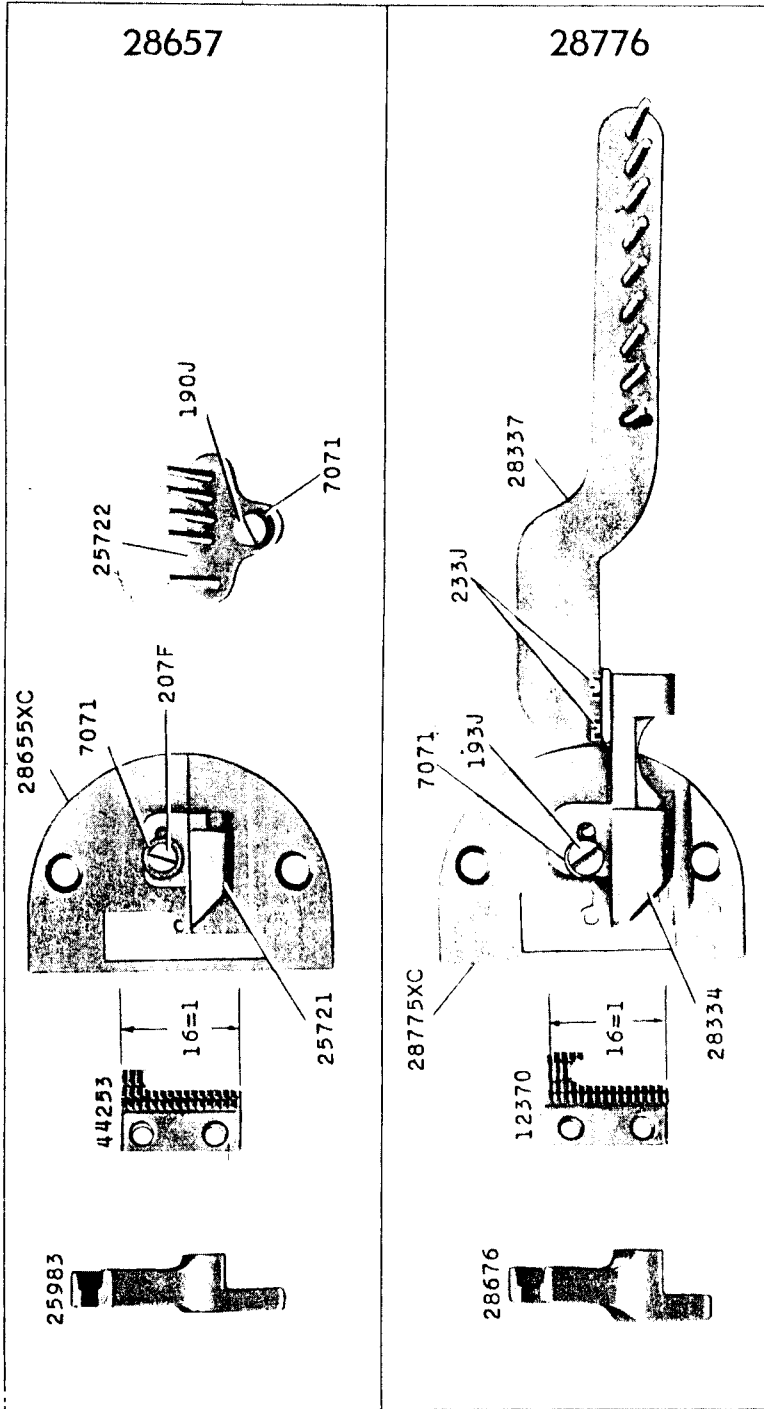

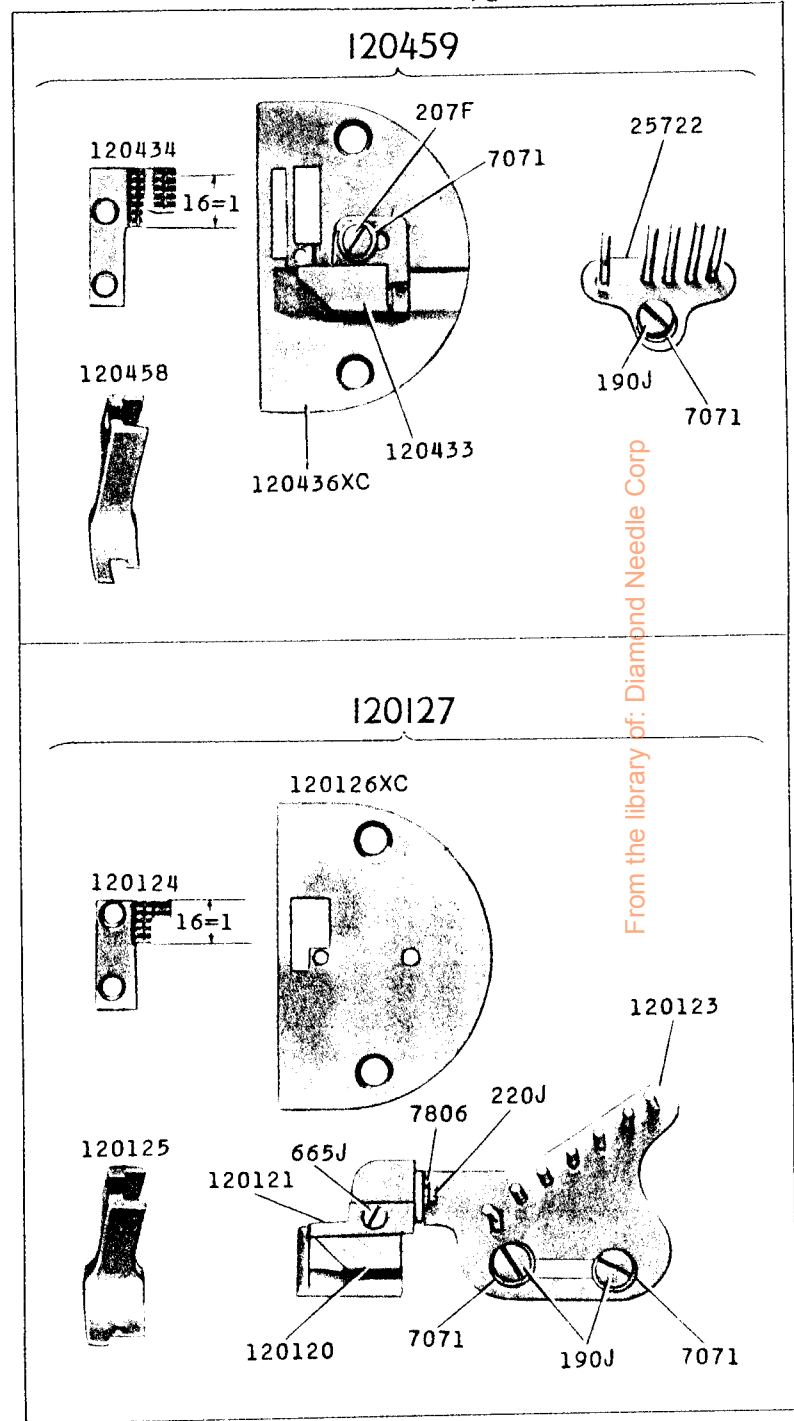
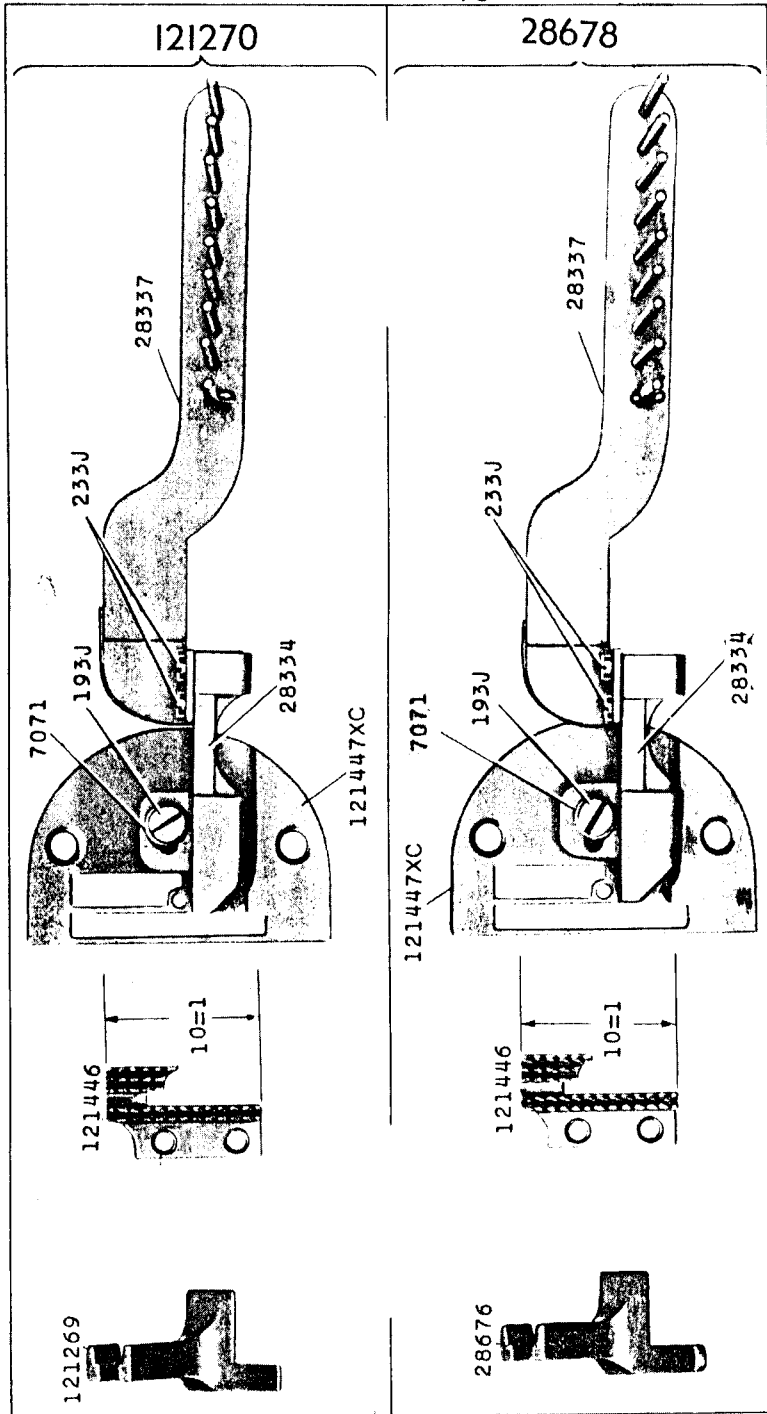

From the library of: Diamond Needle Corp

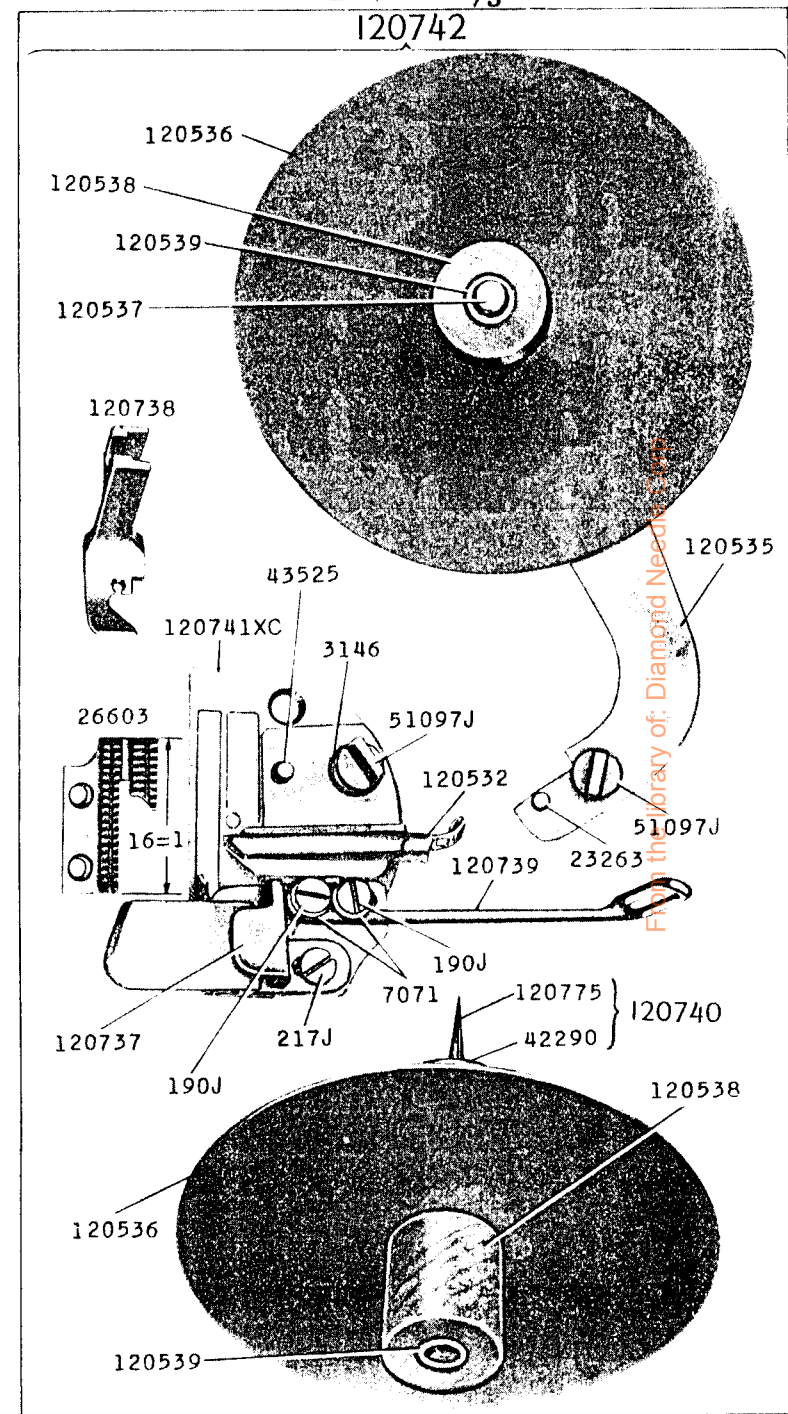
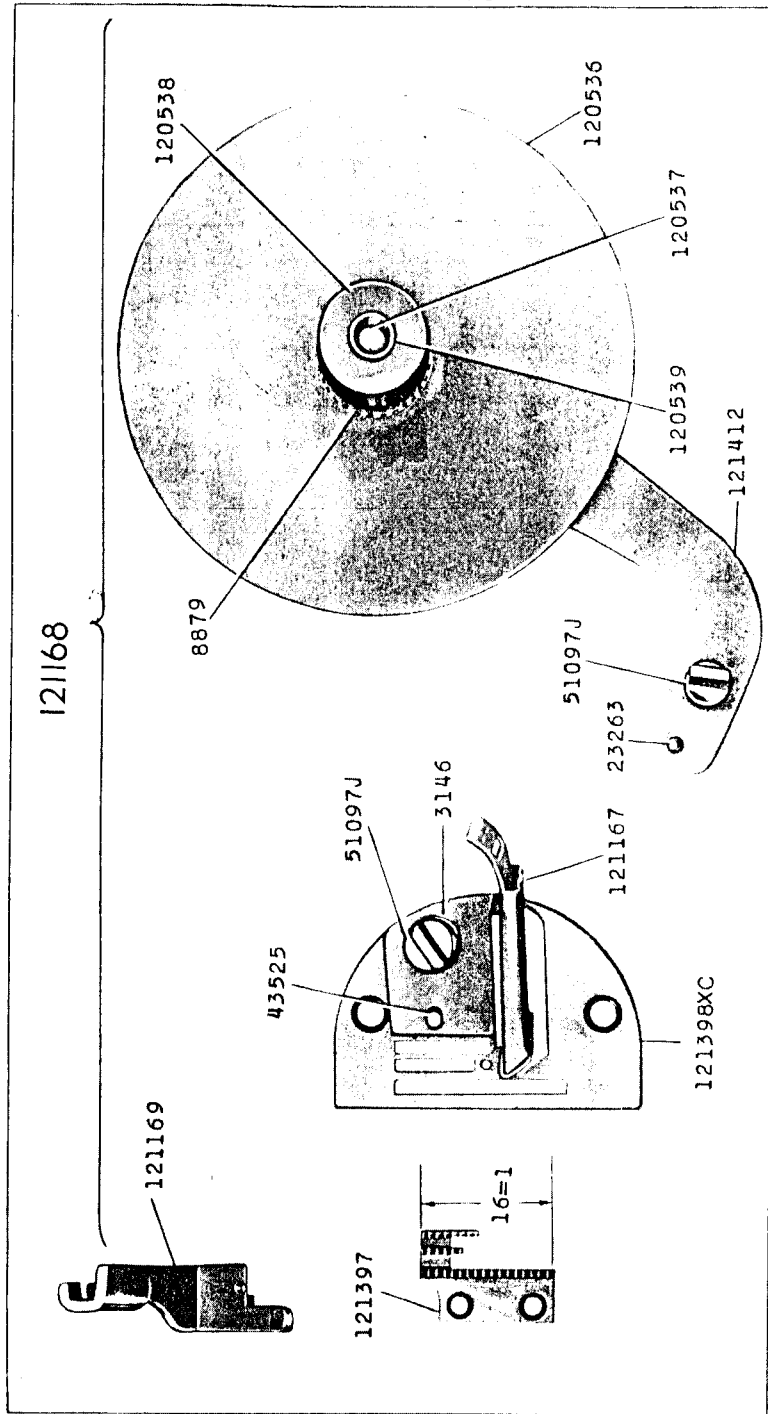



22921 - 2/3

120801

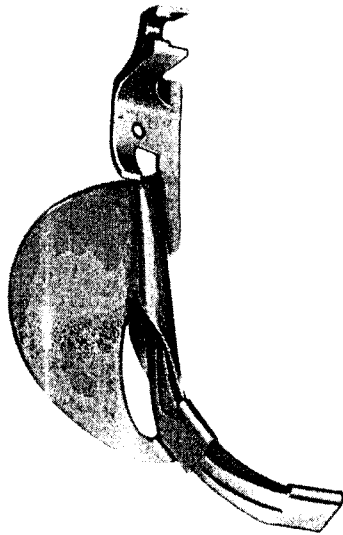

35969

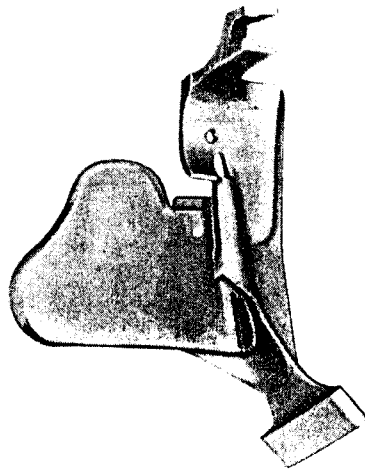

28769



120802

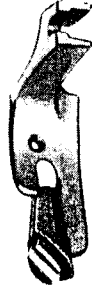

36700

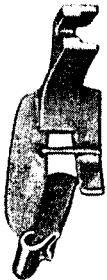

28717



22922 - 1/2

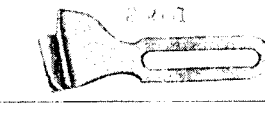
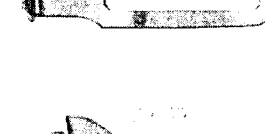
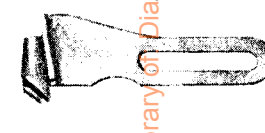
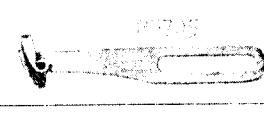
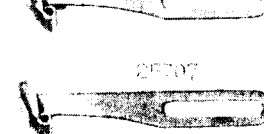
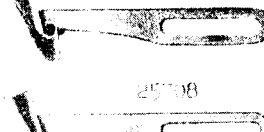
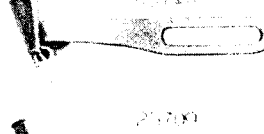
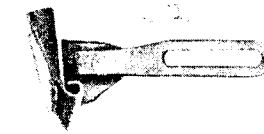
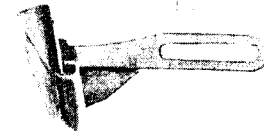
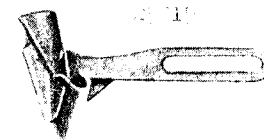

From the library of Diamond Needle Corp

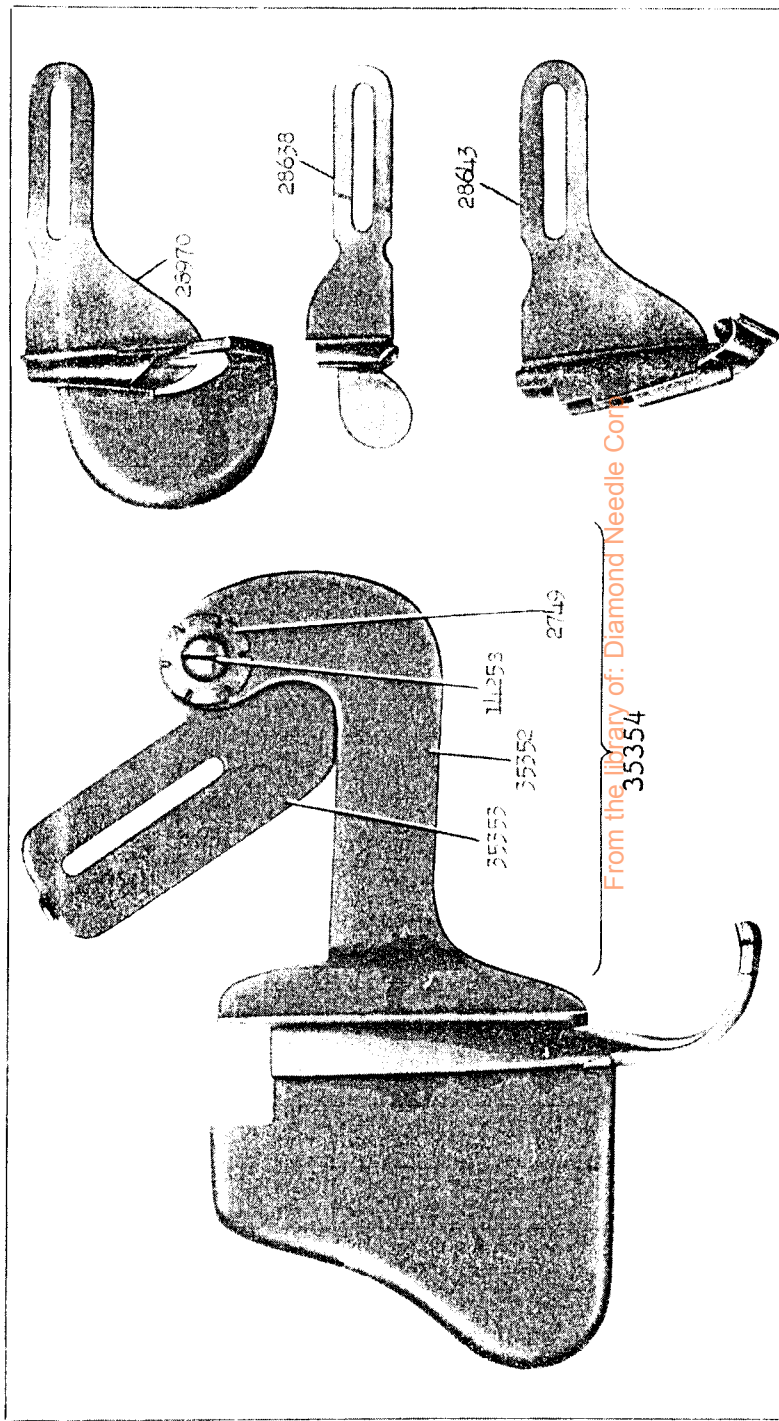
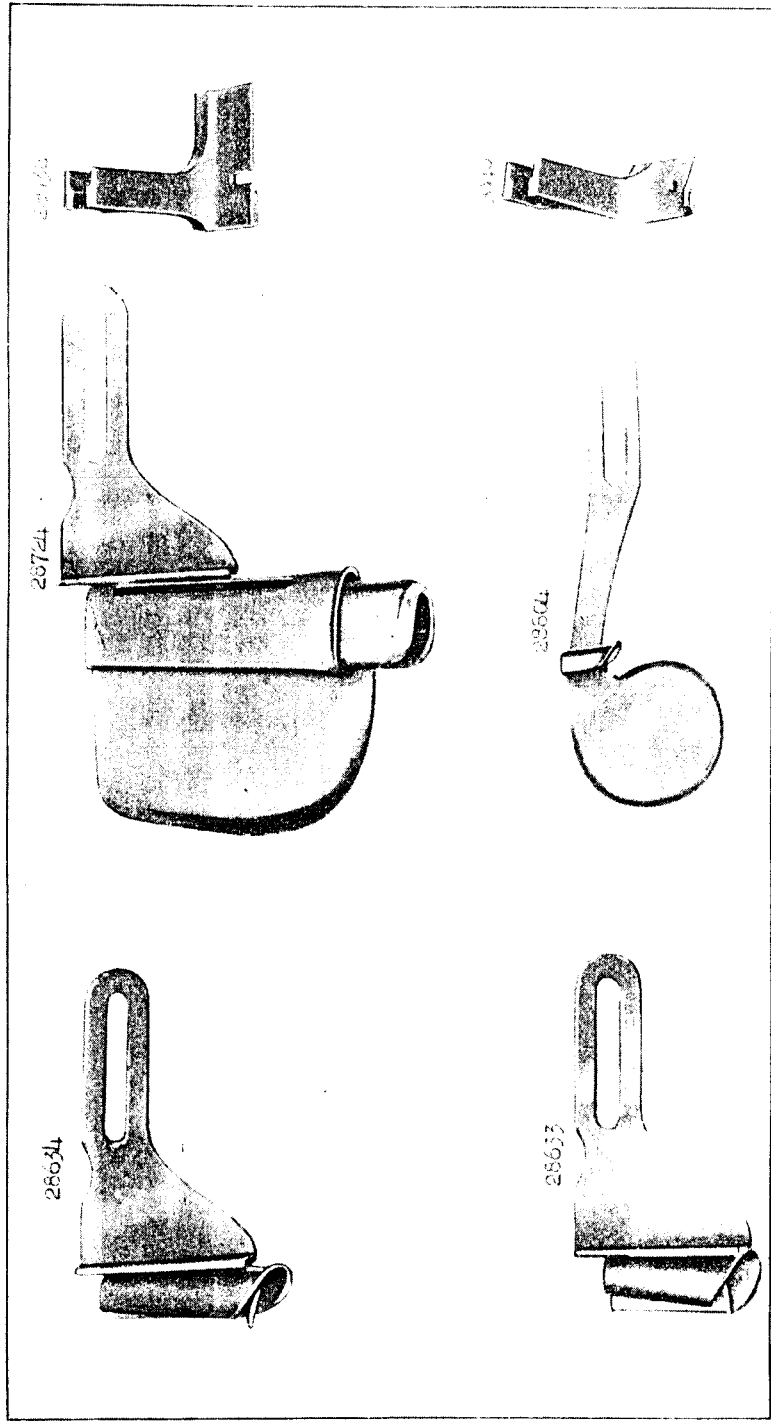

From the library of: Diamond Needle Corp  
35354

22925 - 2/3

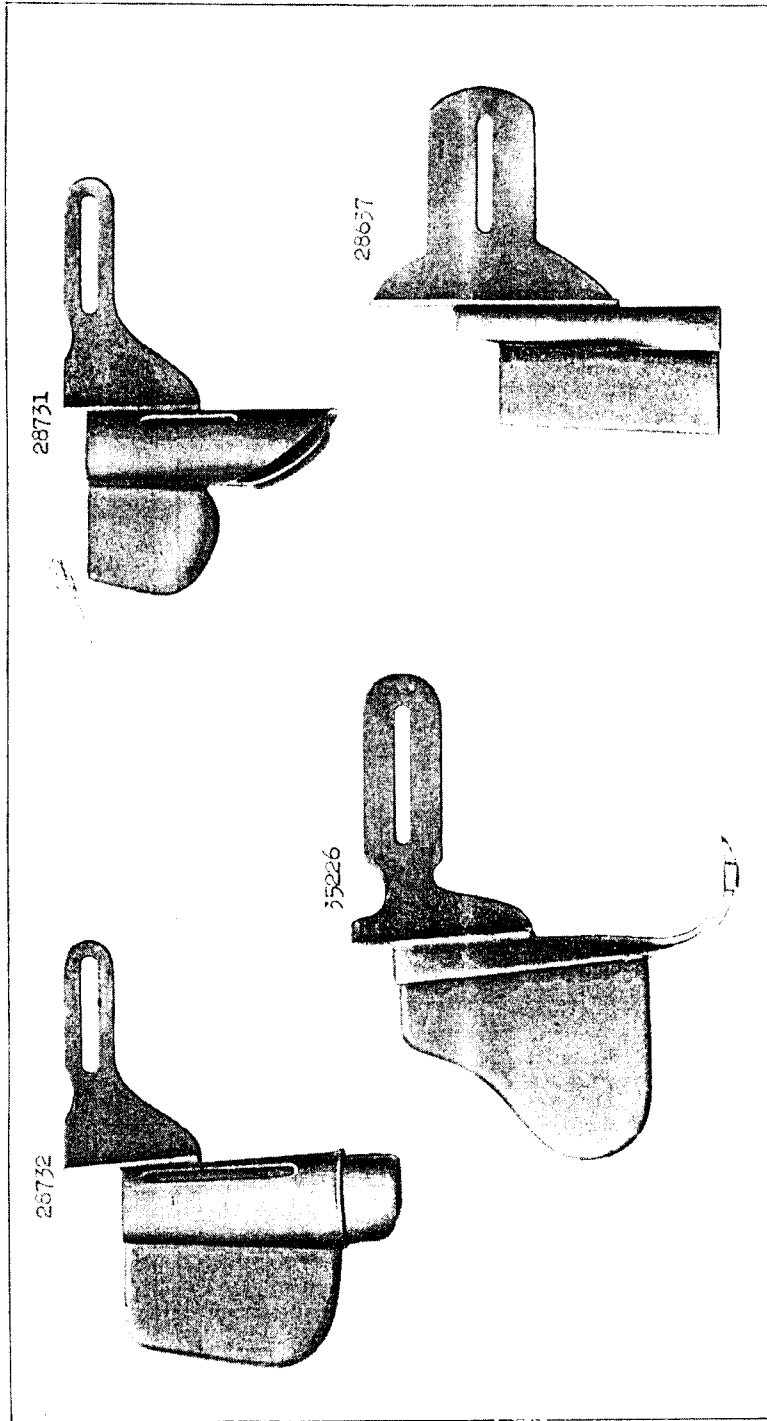

22926 - 2/3

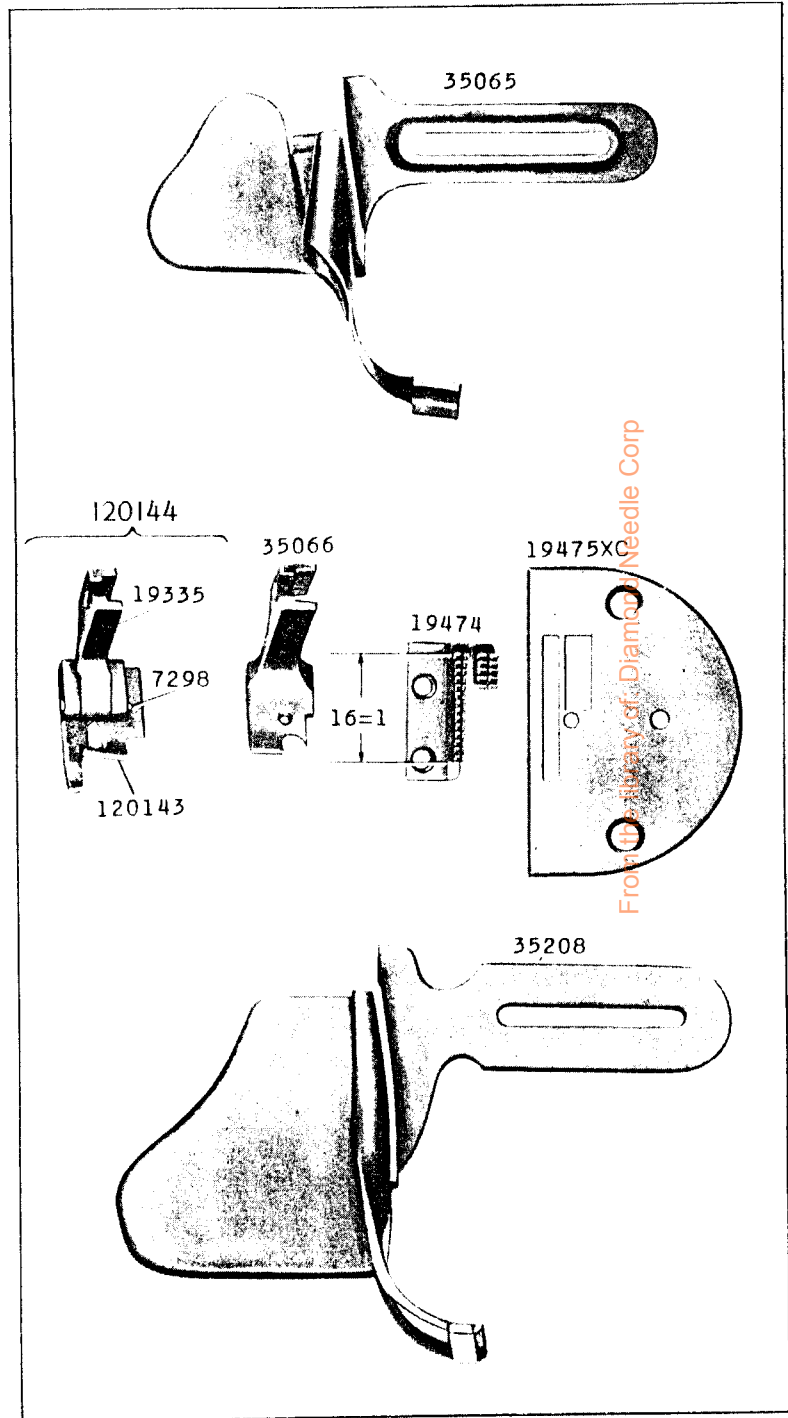

From the Library of Diamond Needle Corp

22927 - 2/3

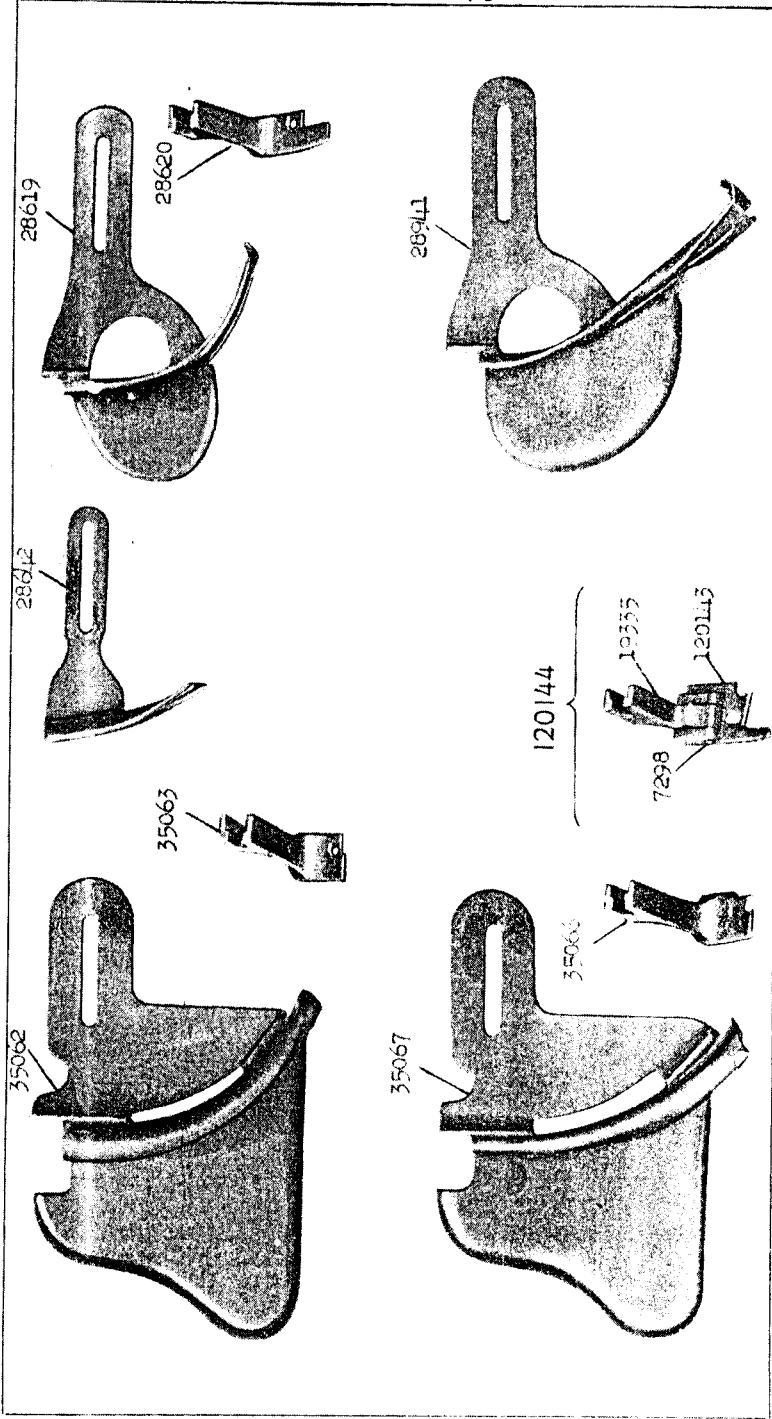

22929 - 1/2

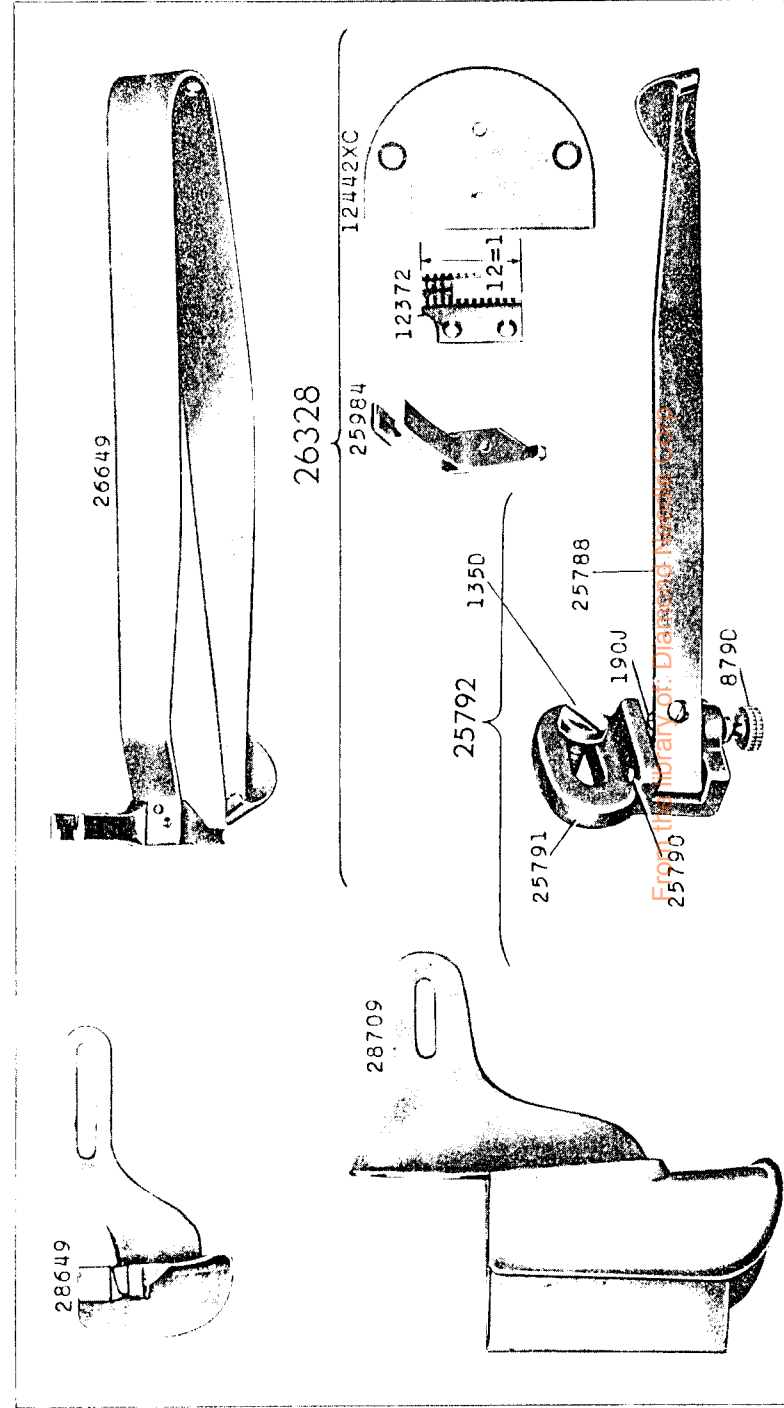

22930 - 1/2

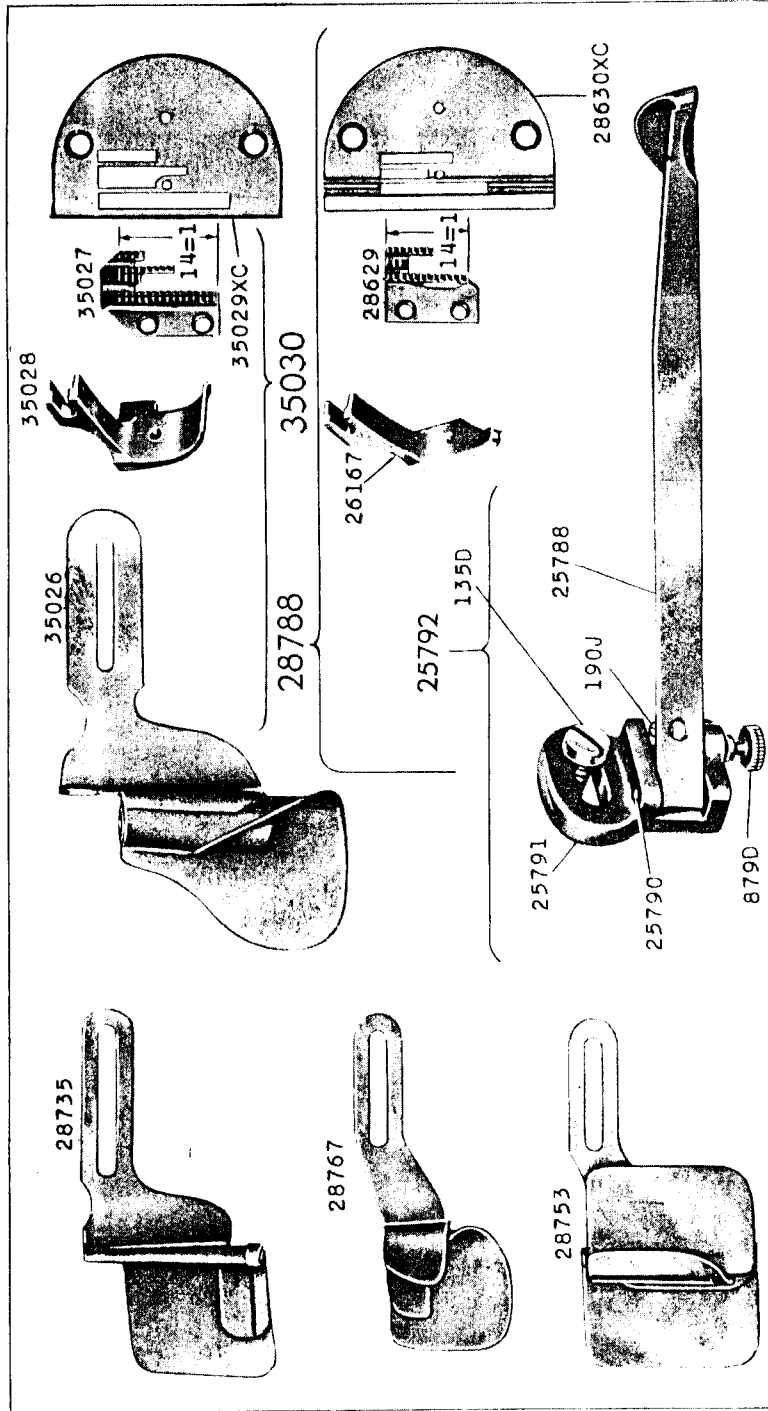

22931 - 2/3

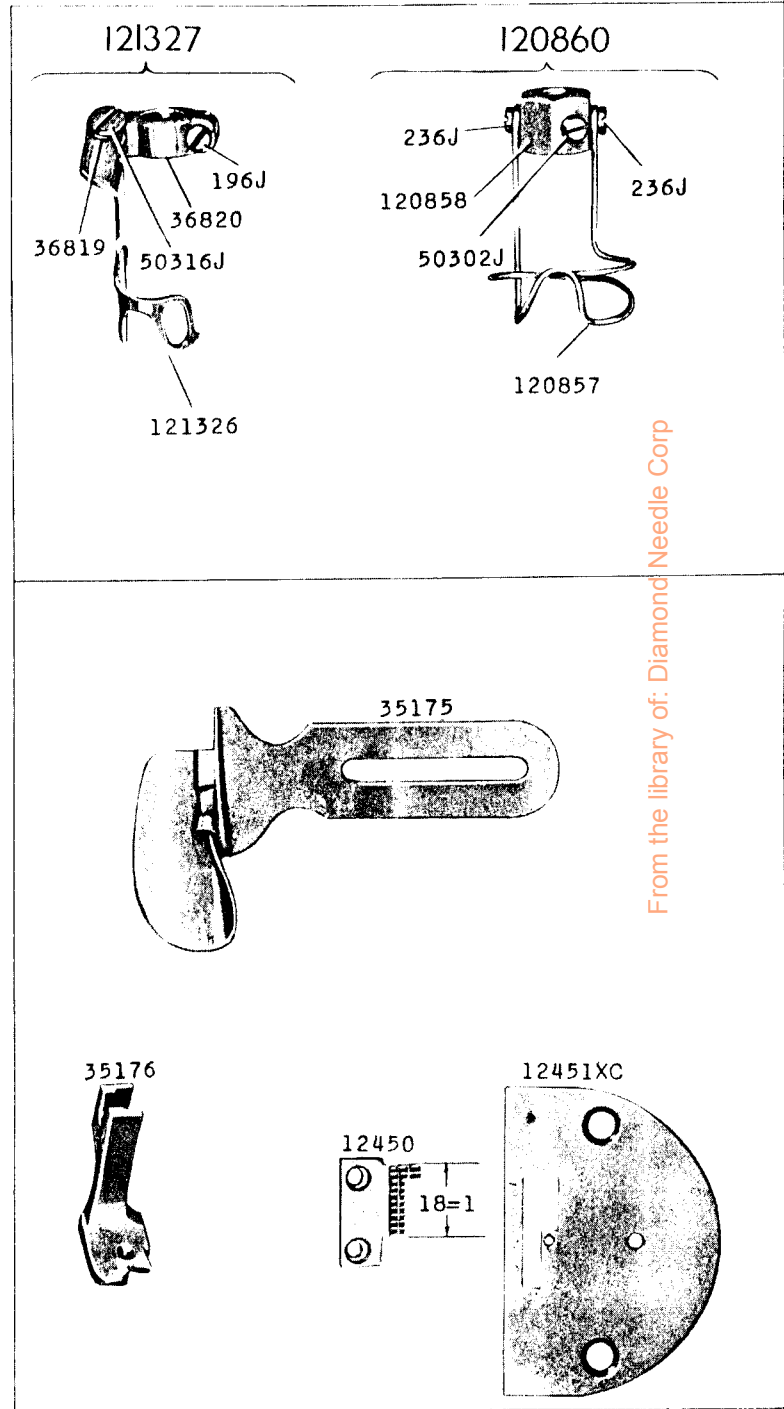

From the library of: Diamond Needle Corp

22932 - 2/3

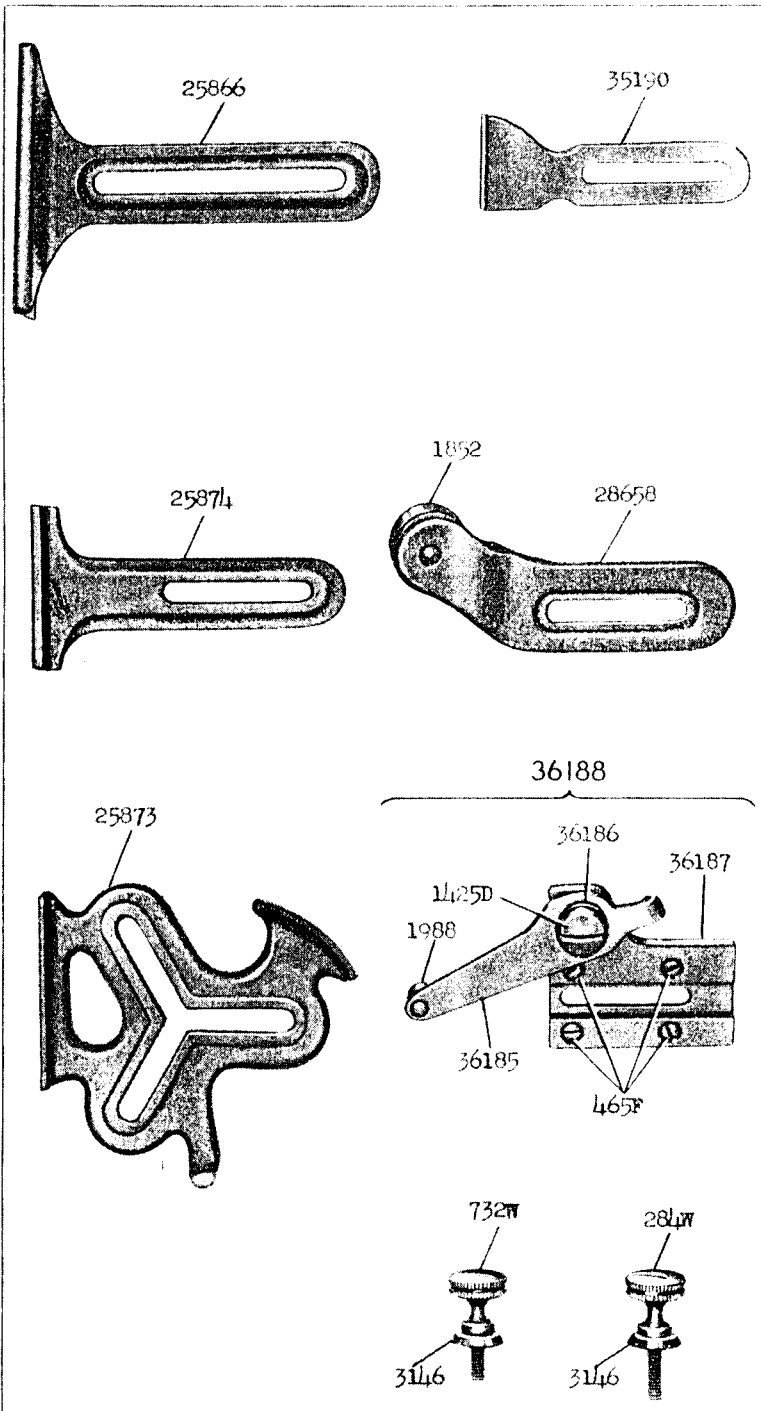

22933 - 2/3

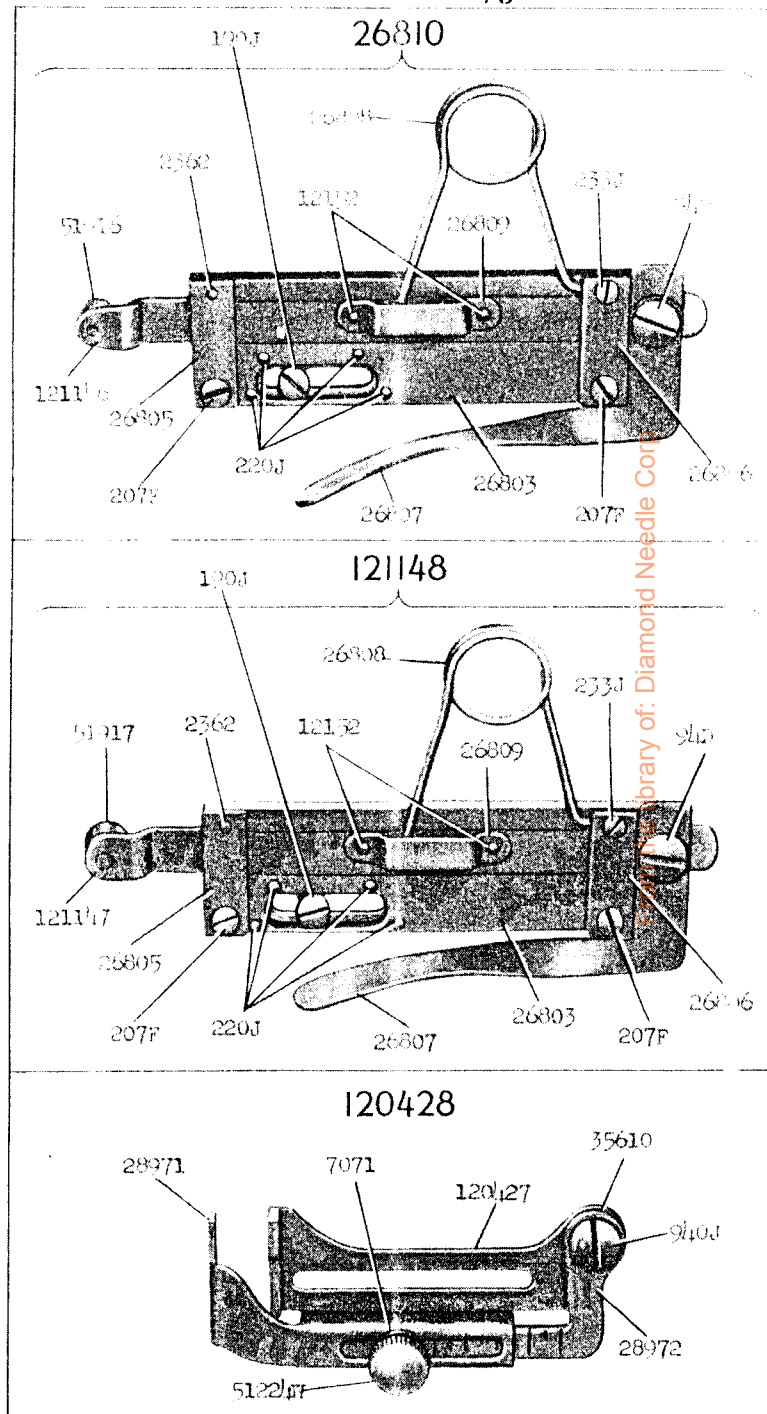

Library of: Diamond Needle Corp.

22934 - 2/3

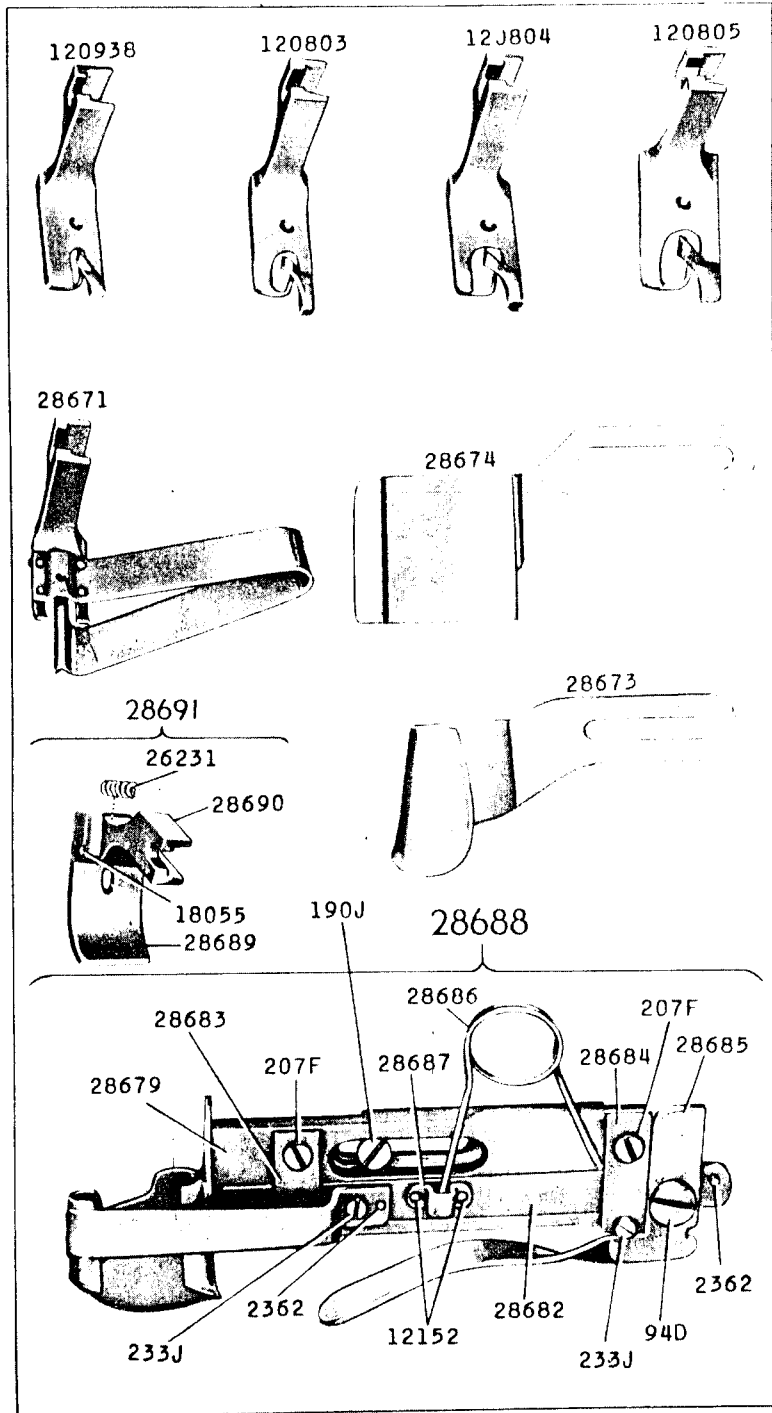

22935 - 2/3

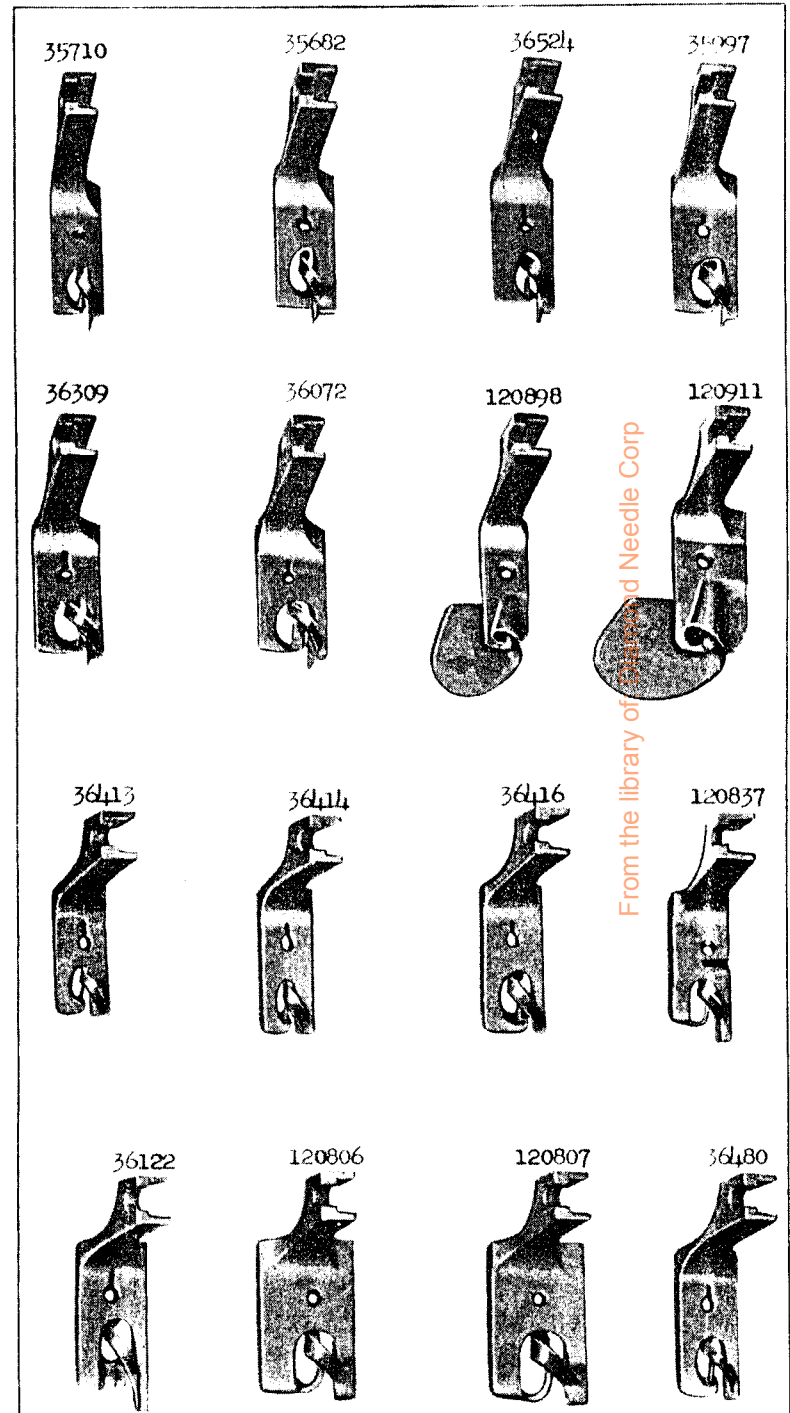

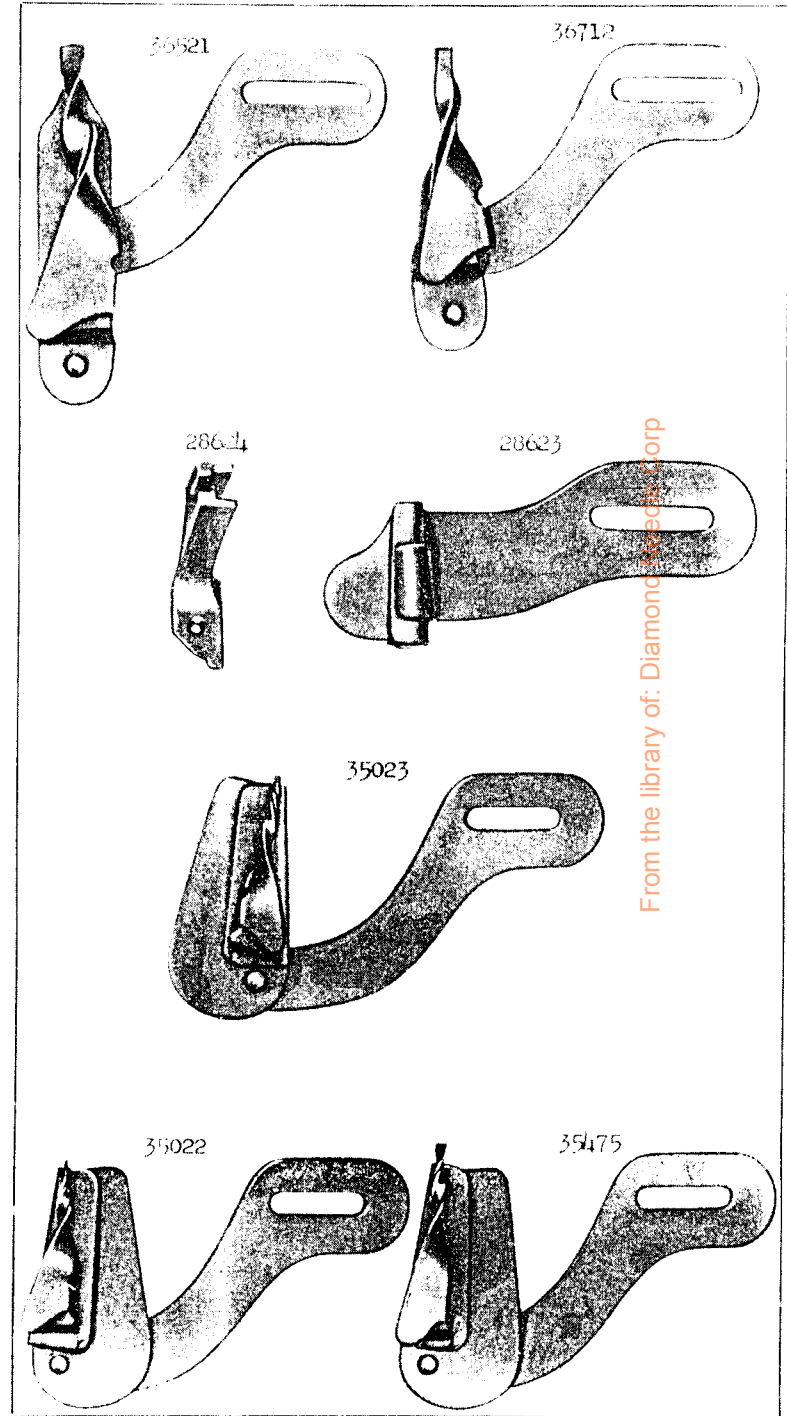
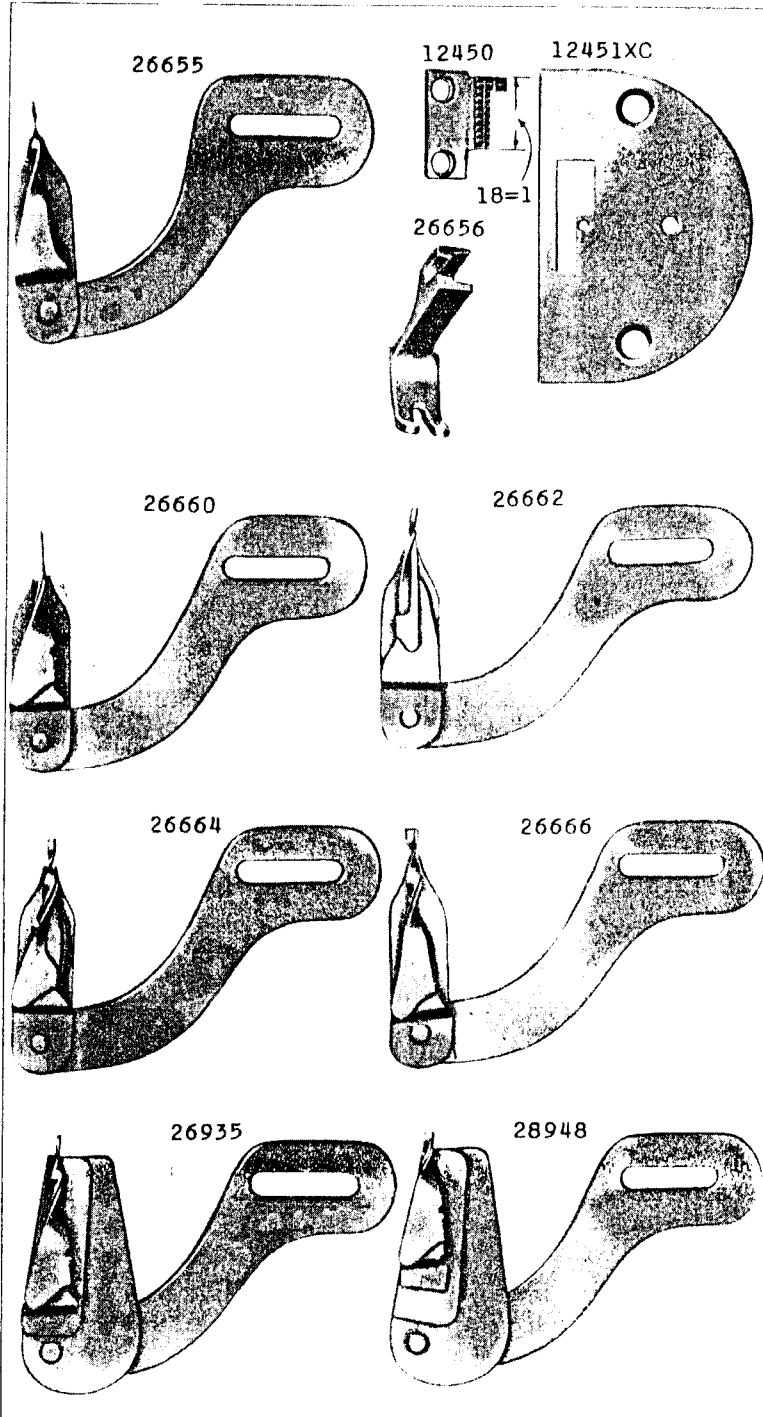

From the library of: Diamond Speedy Corp



22938 - 2/3

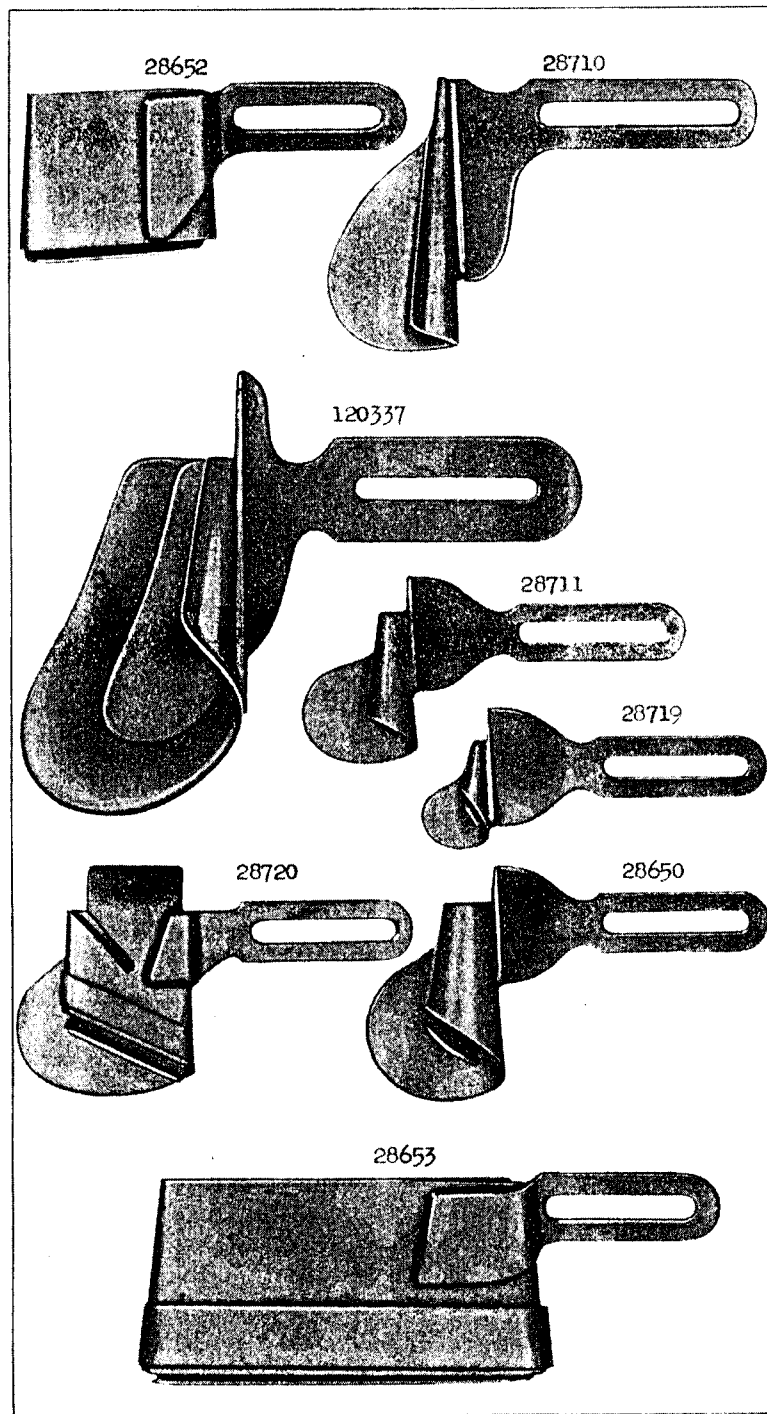

22939 - 2/3

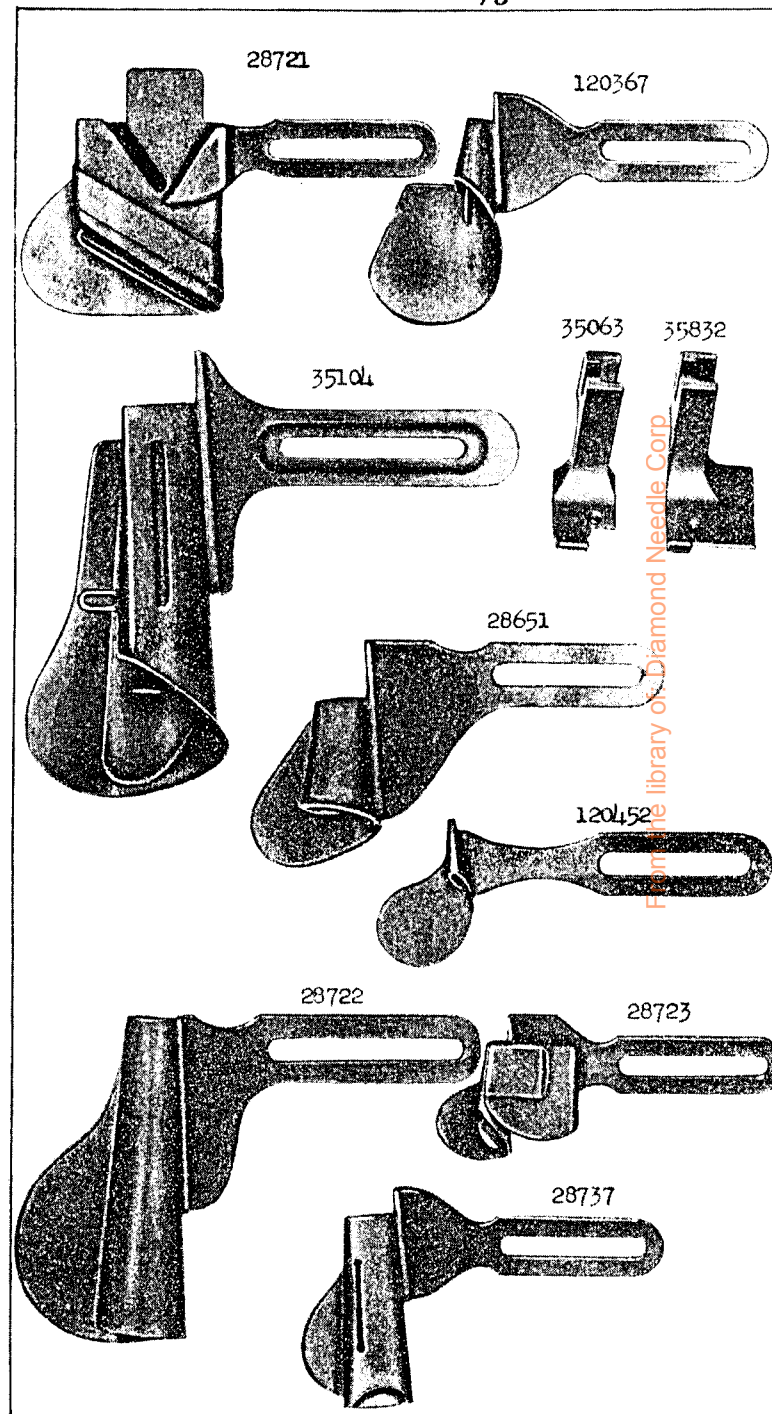

From the library of Diamond Needle Corp

22940 - 2/3

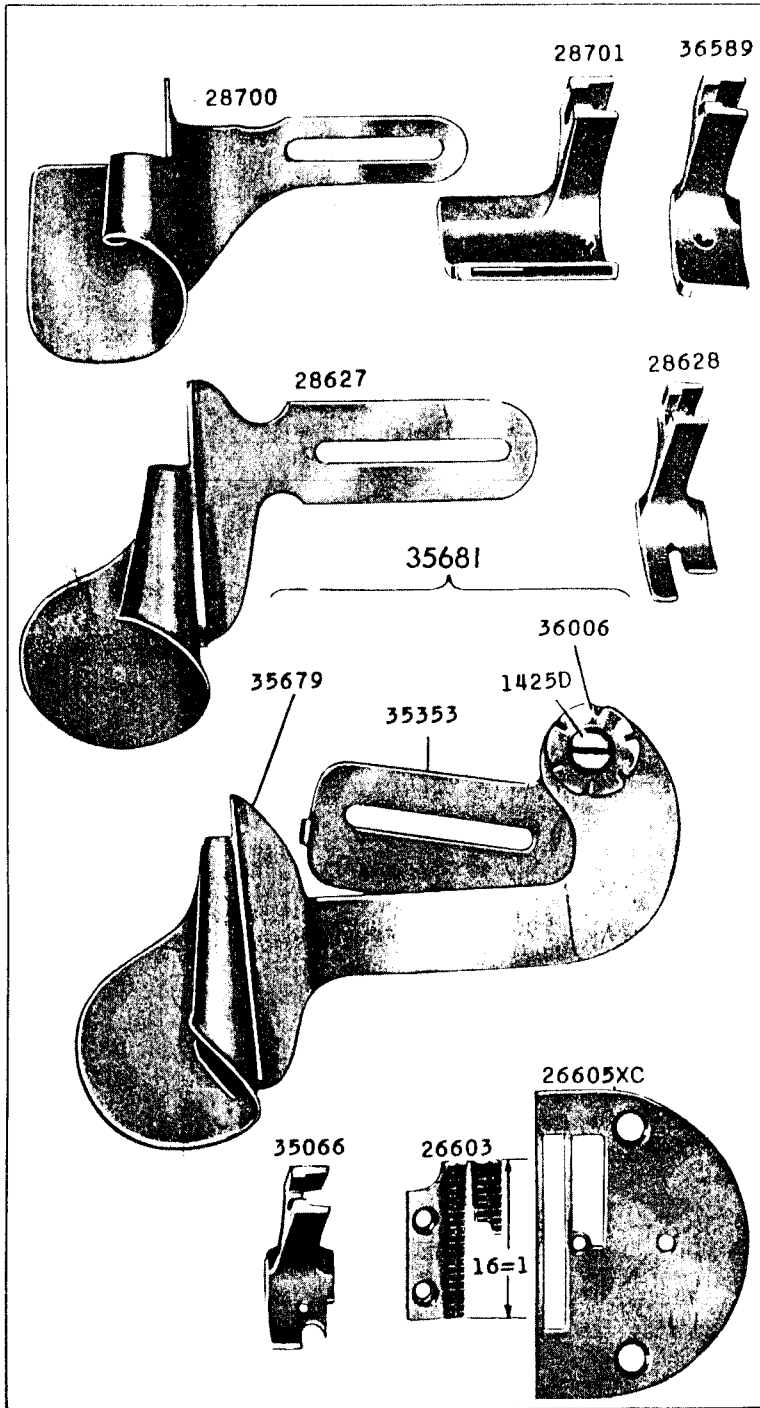

22941 - 1/2

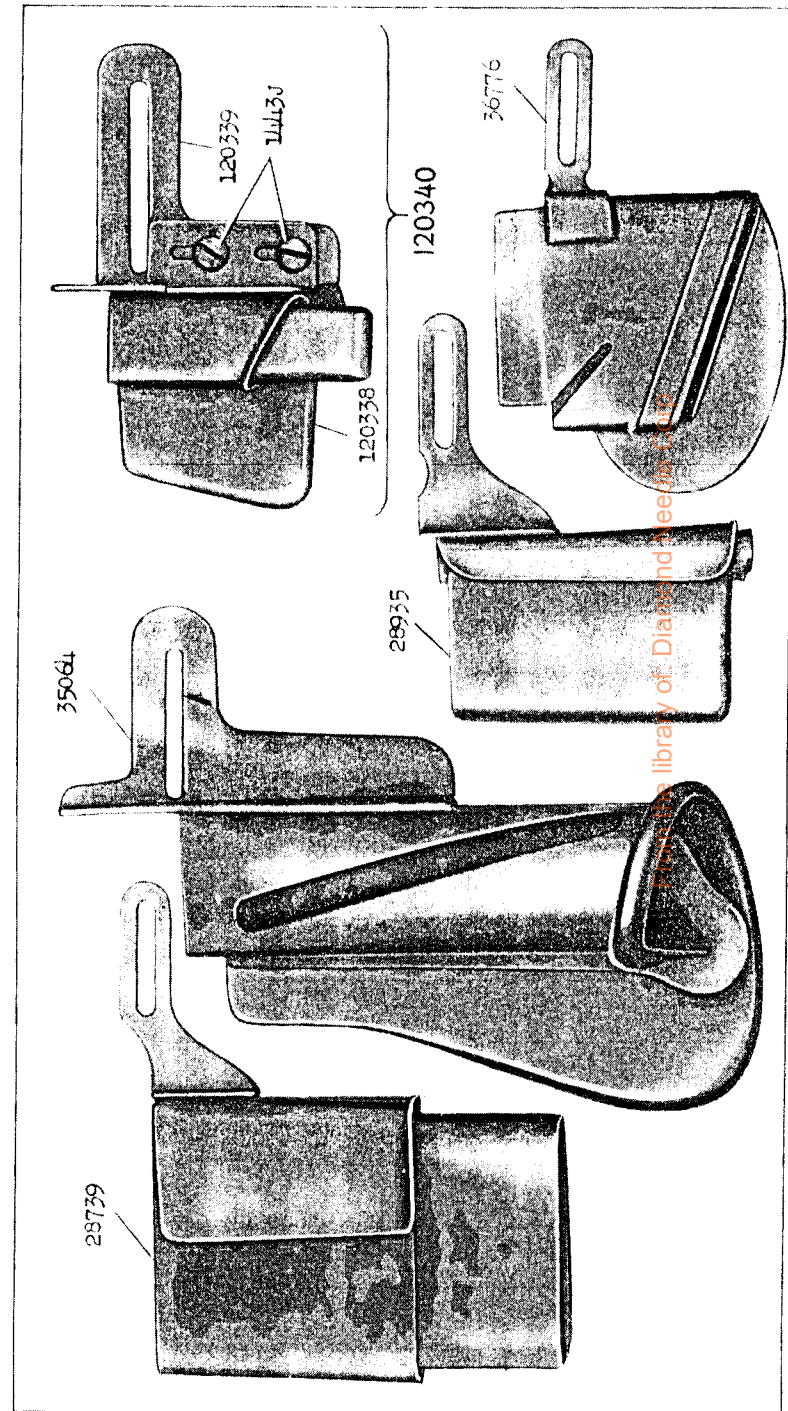

22942 - 2/3

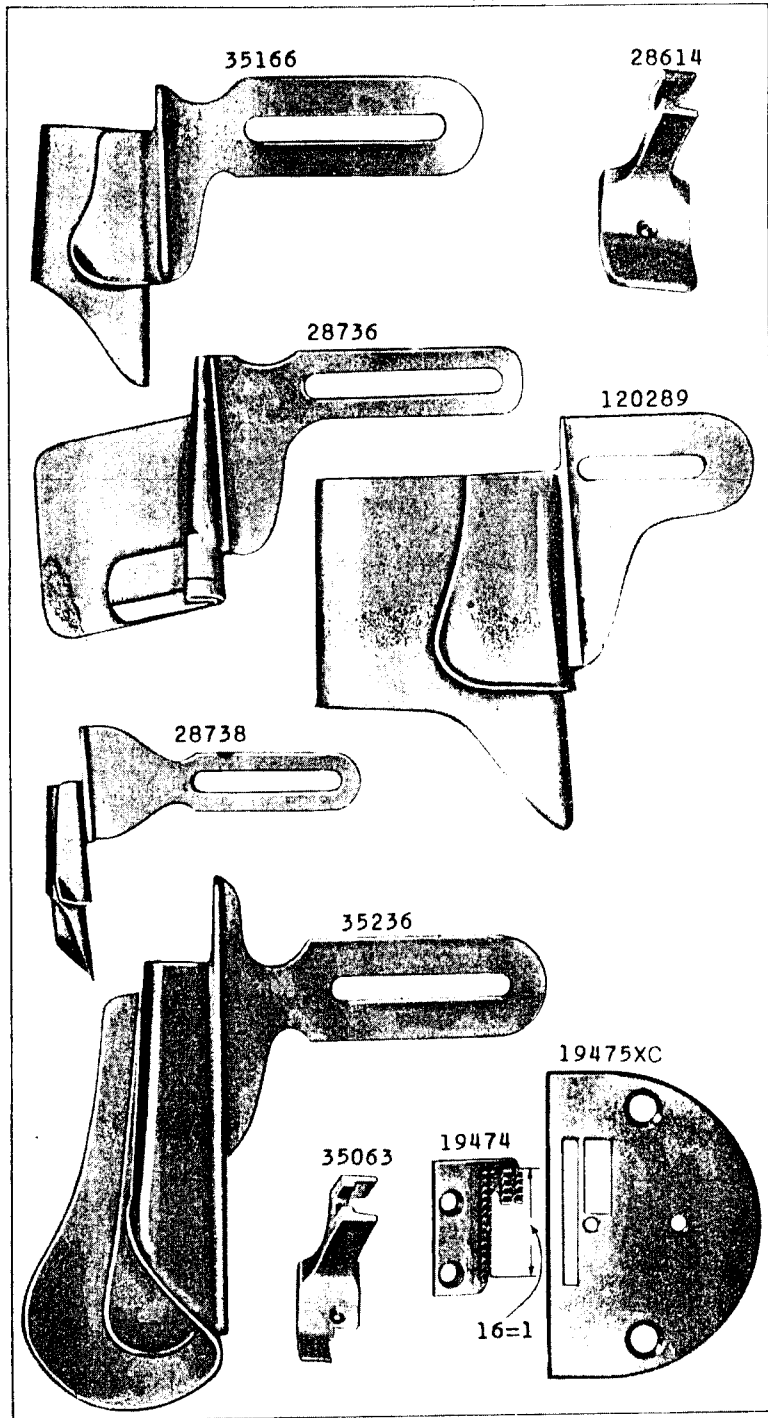

22943 - 2/3

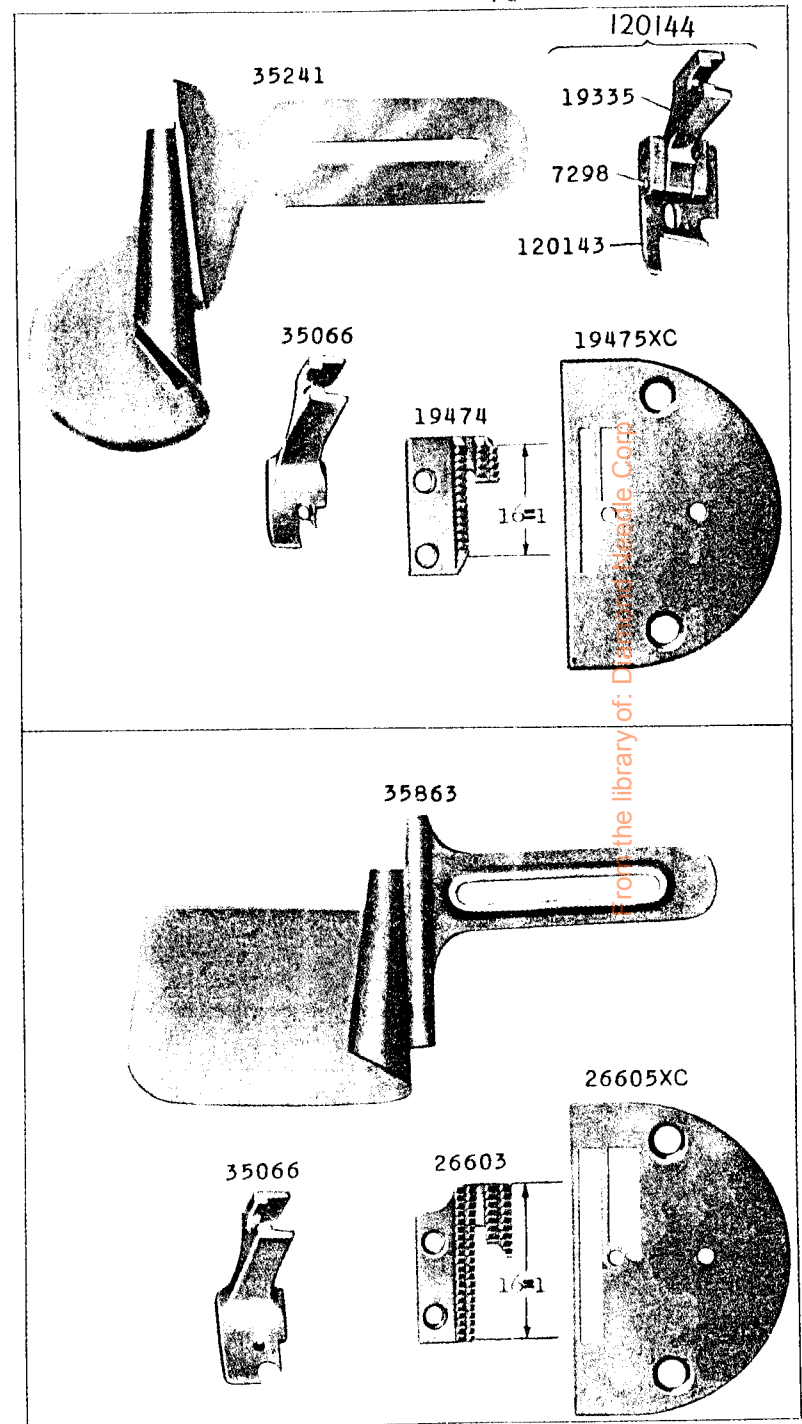

from the library of: Dresser Industries Corp.

22944 - 2/3

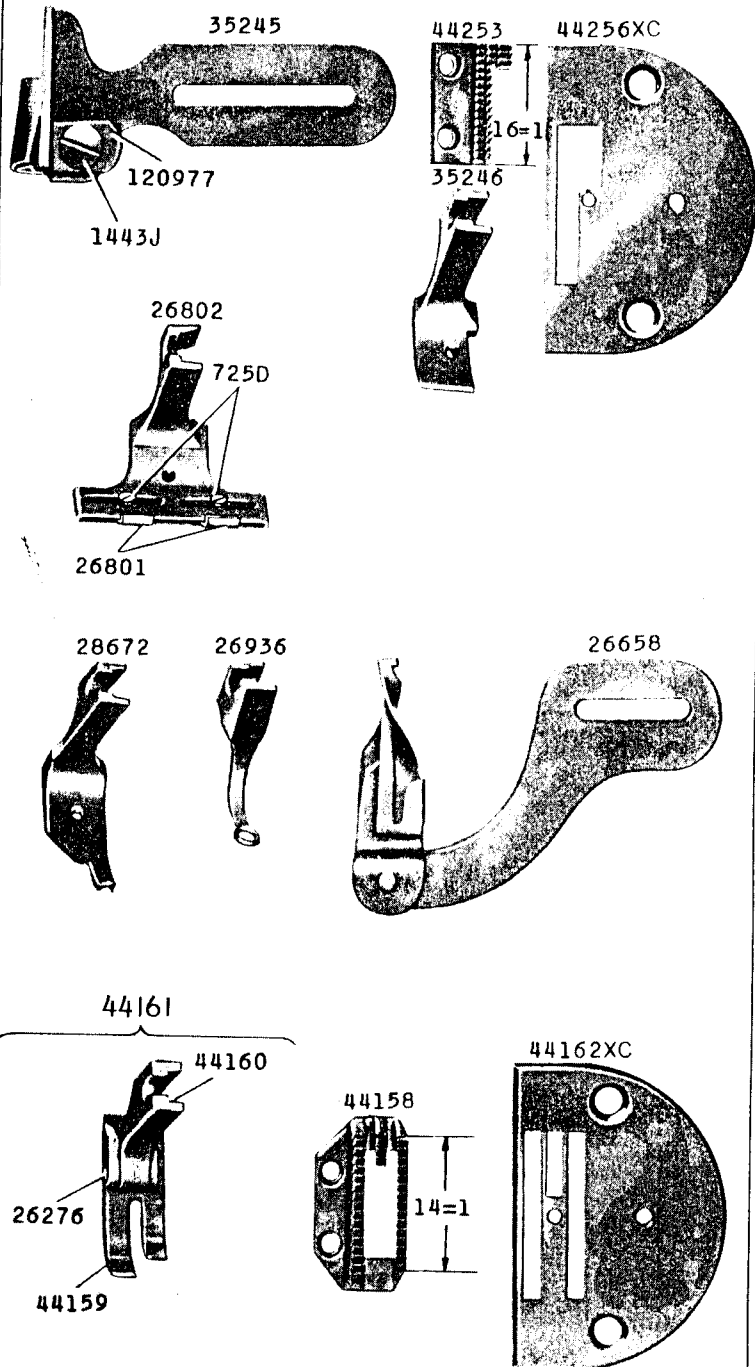

22945 - 2/3

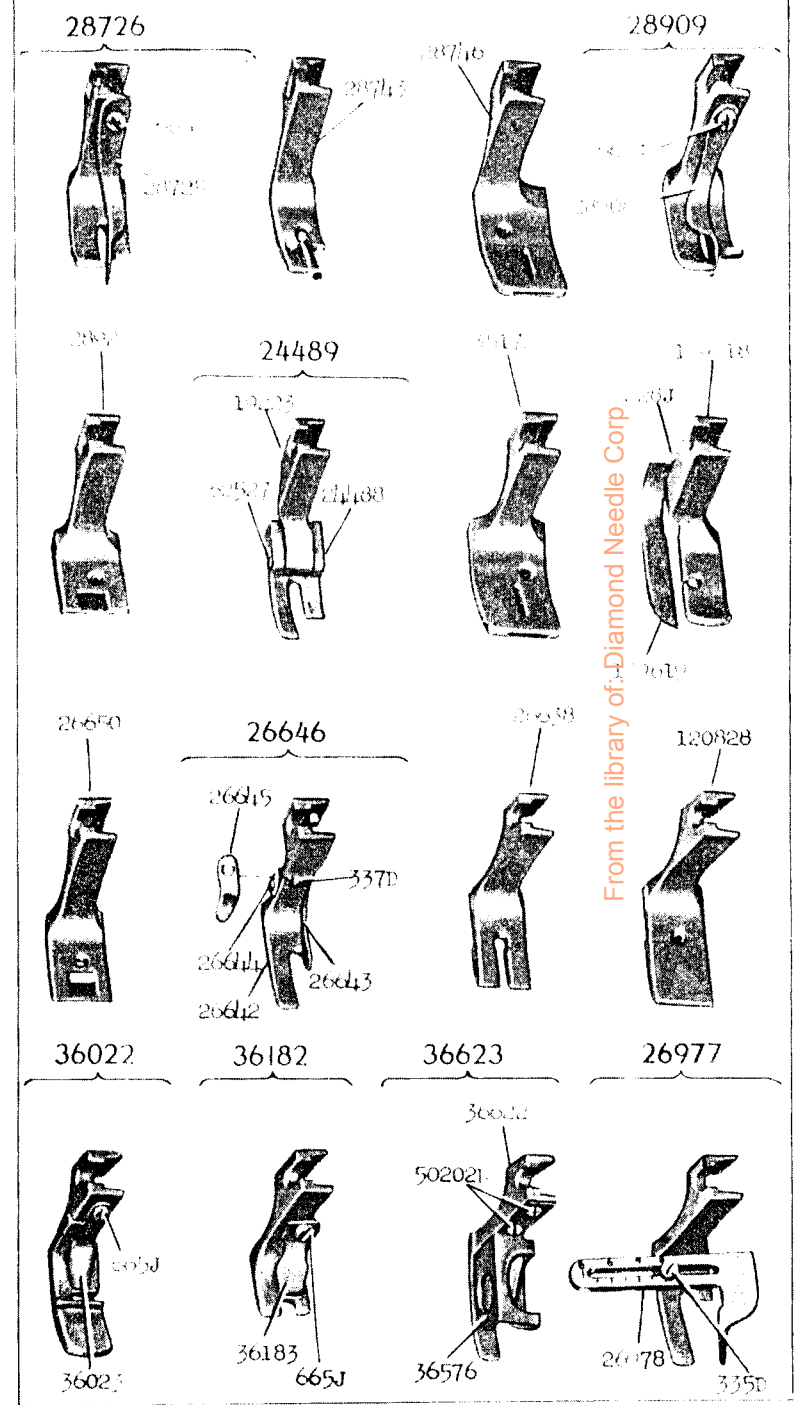

From the library of Diamond Needle Corp

22946 - 2/3

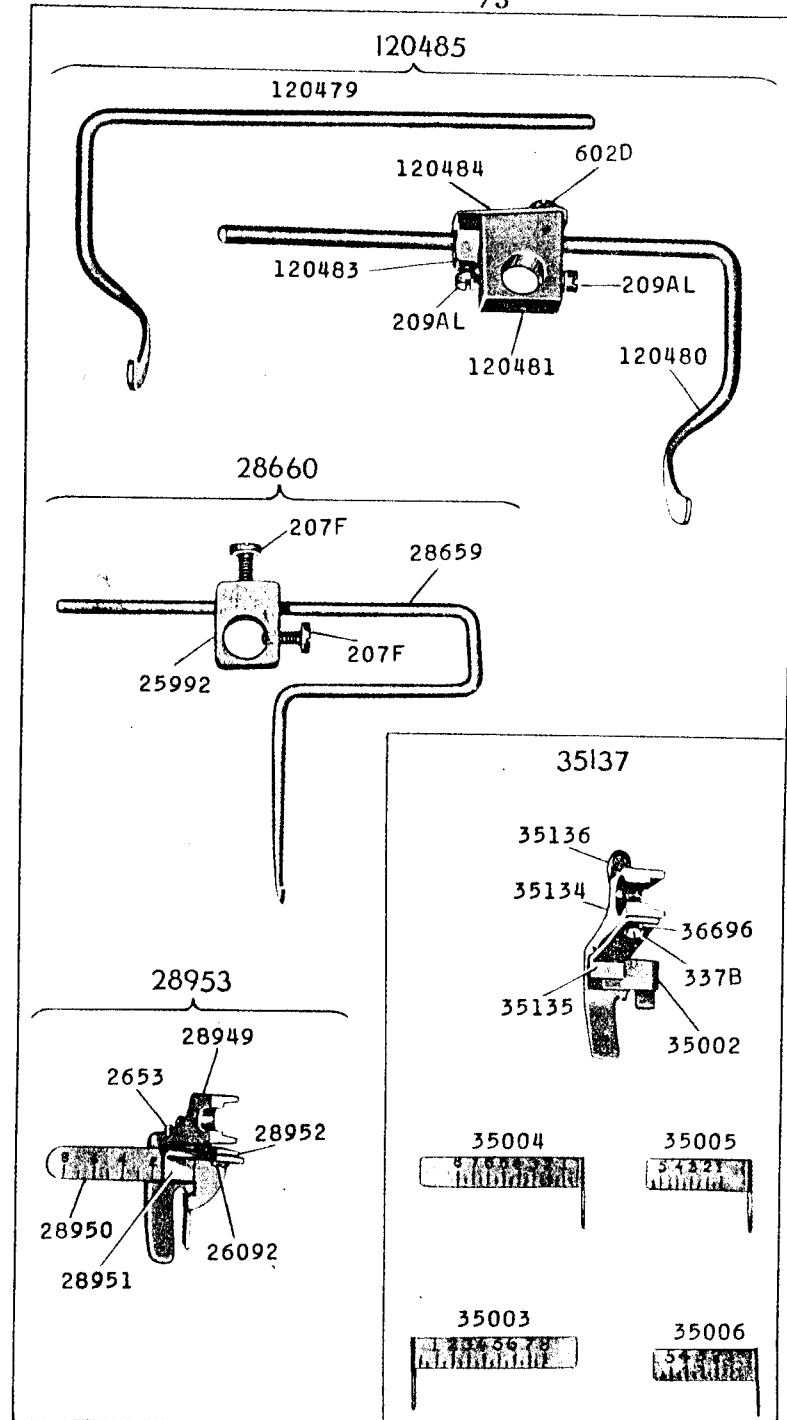

22947 - 2/3

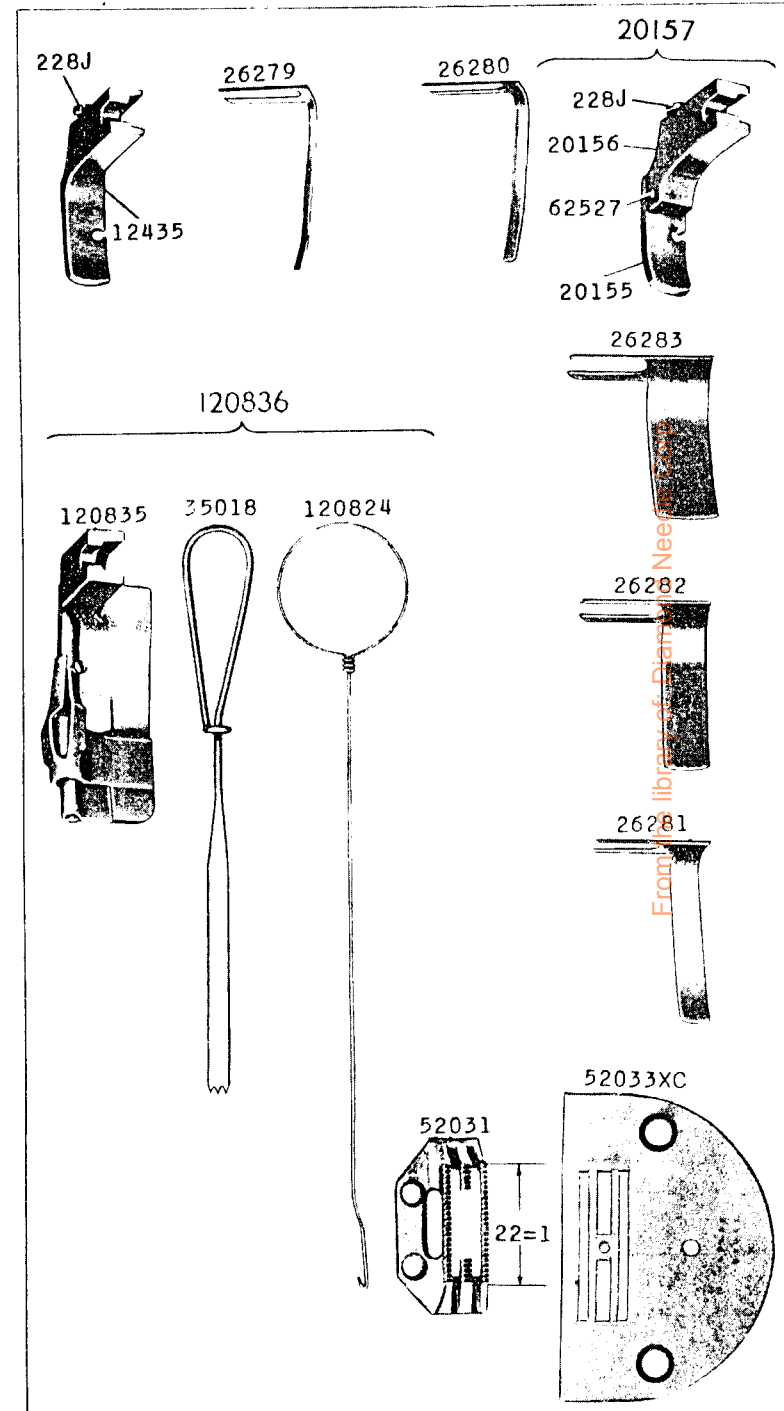

From the Library of Daniel Nee

22948 - 2/3

36561

26719

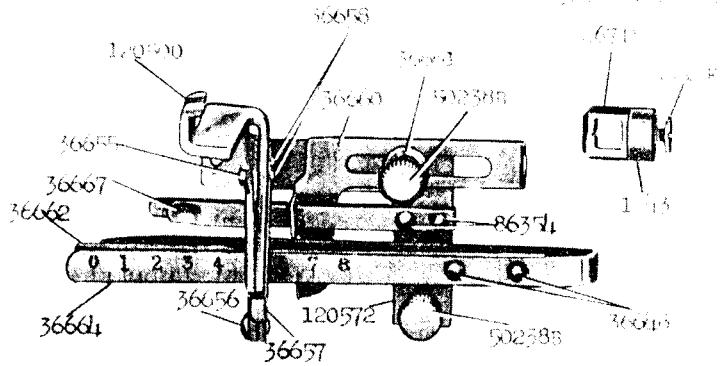

121697

121123

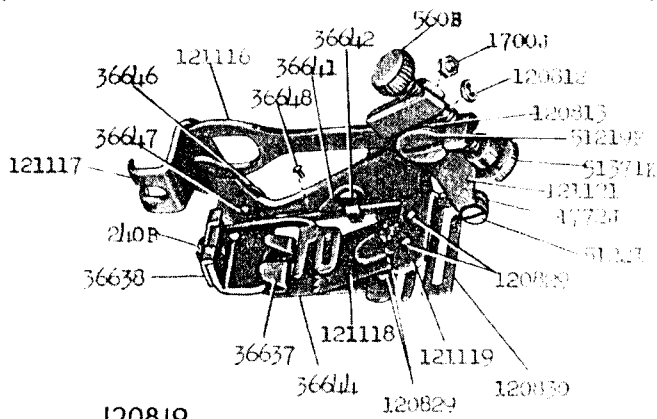

120819

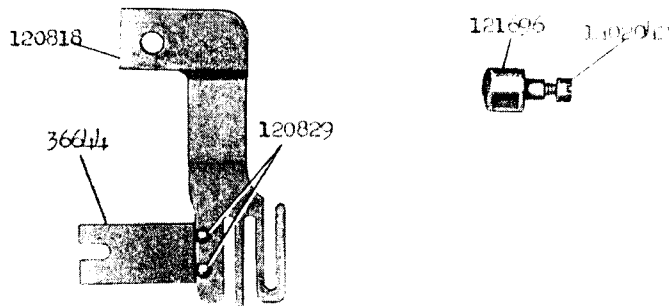

22949 - 2/3

26377

12113

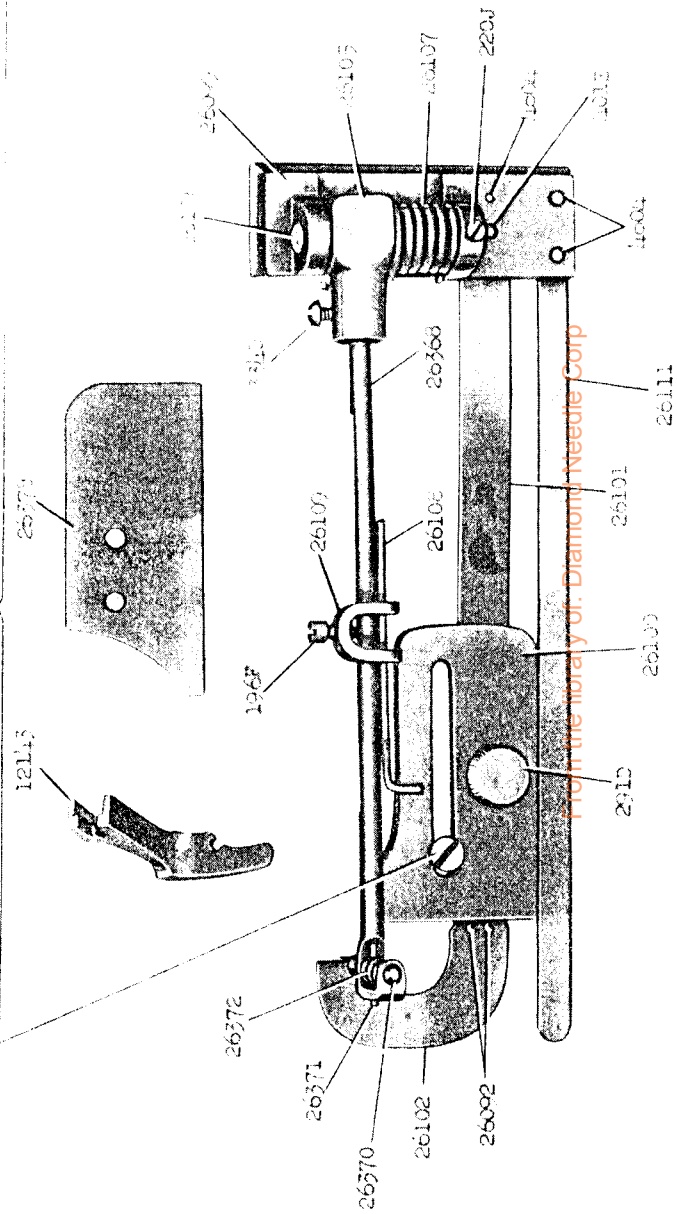

From the library of: Diamond Needle Corp

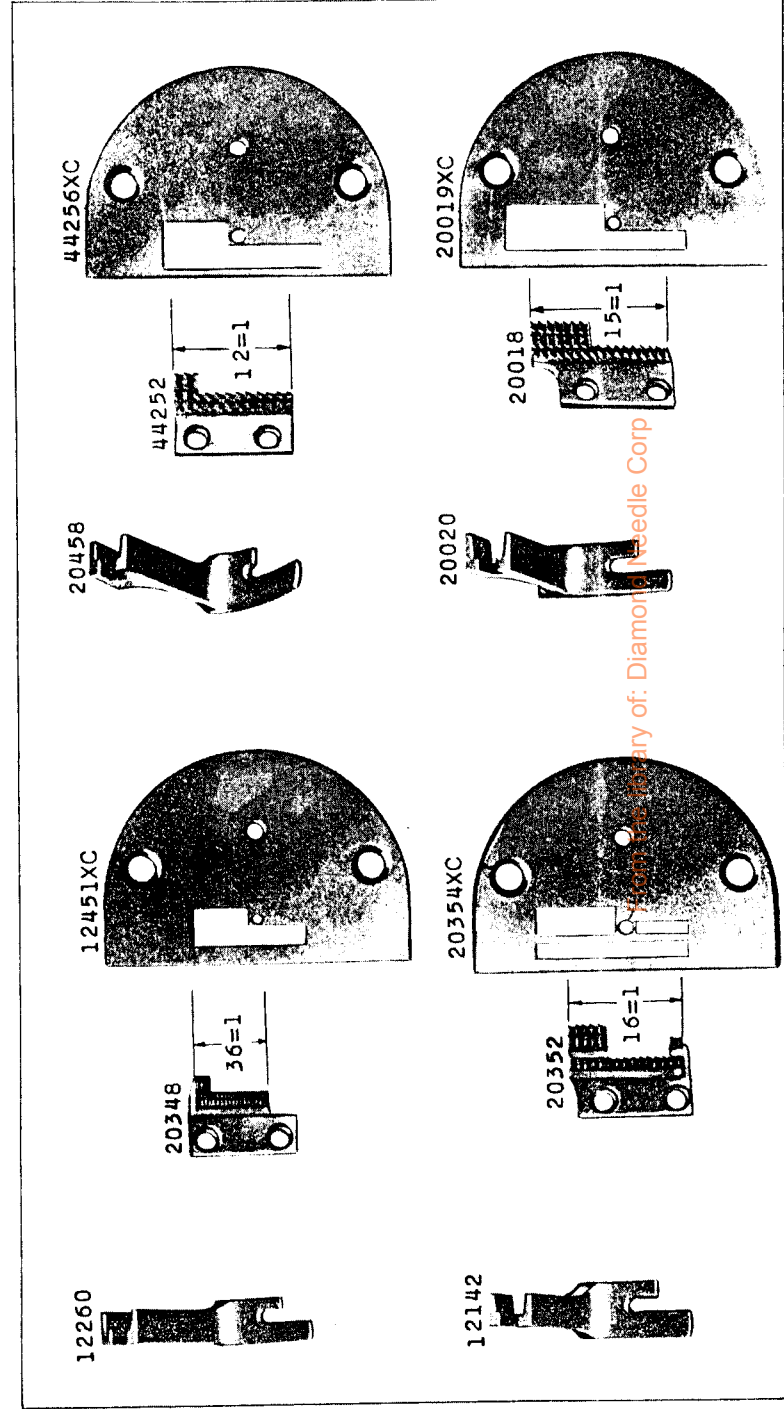
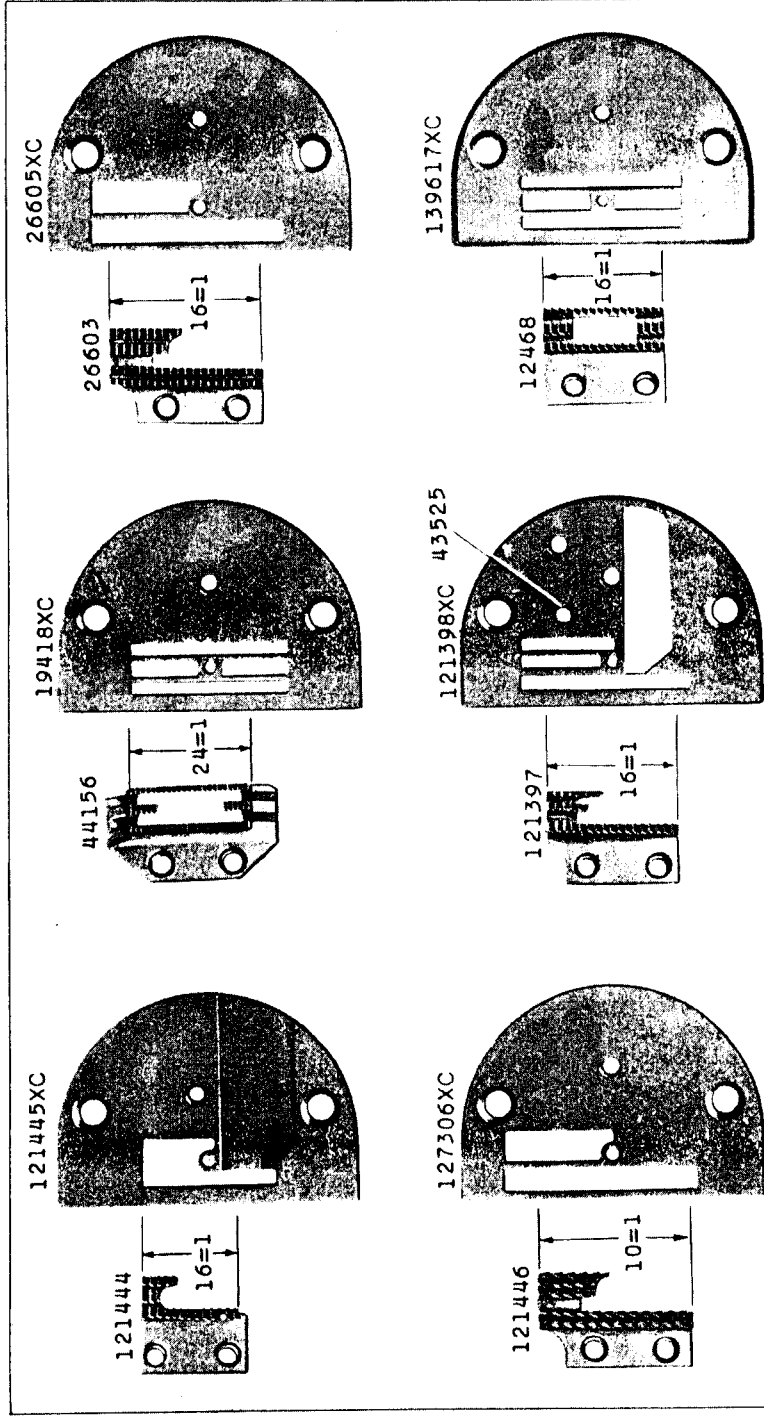

© 2000 Sewing Machine Division of Diamond Needle Corp

22953 - 2/3

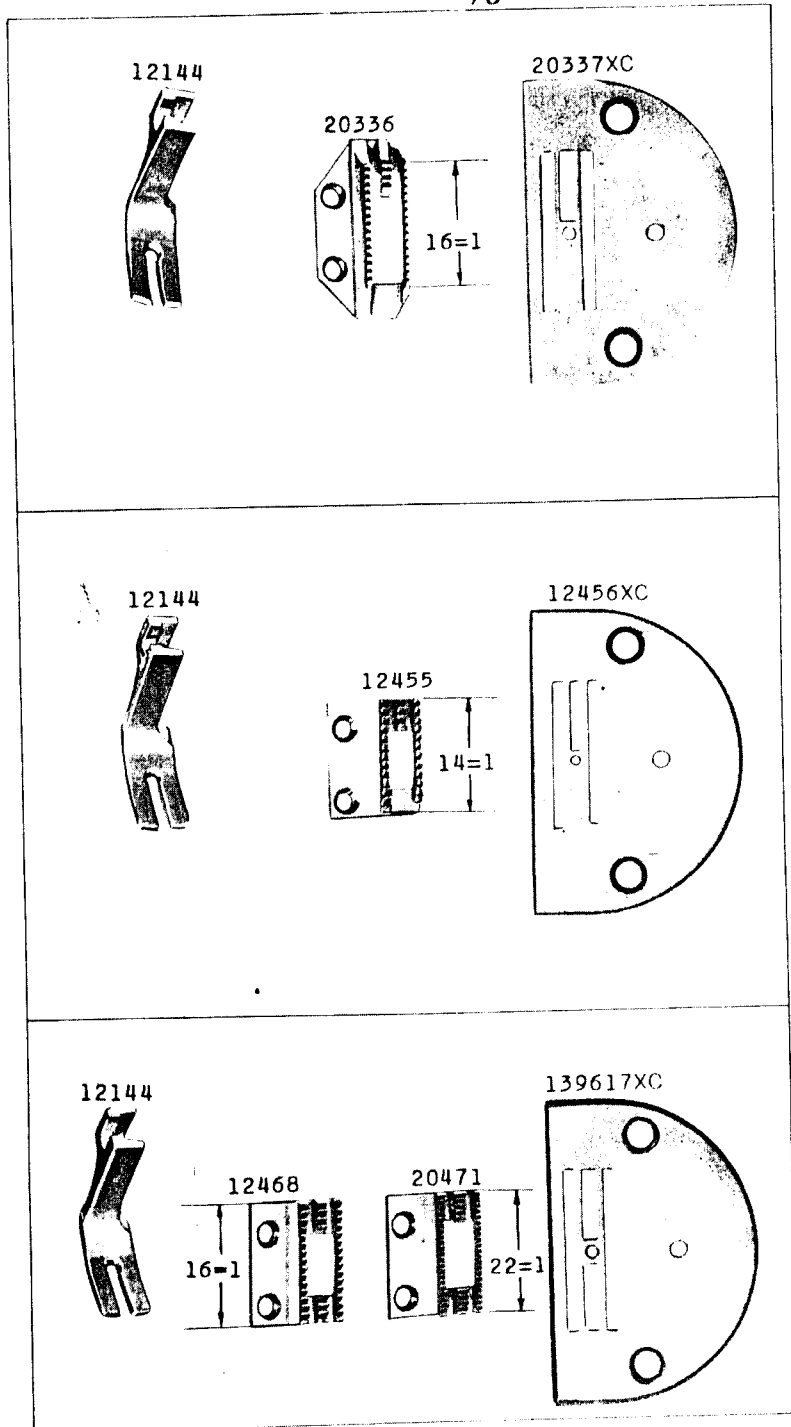

23253 - 3/8

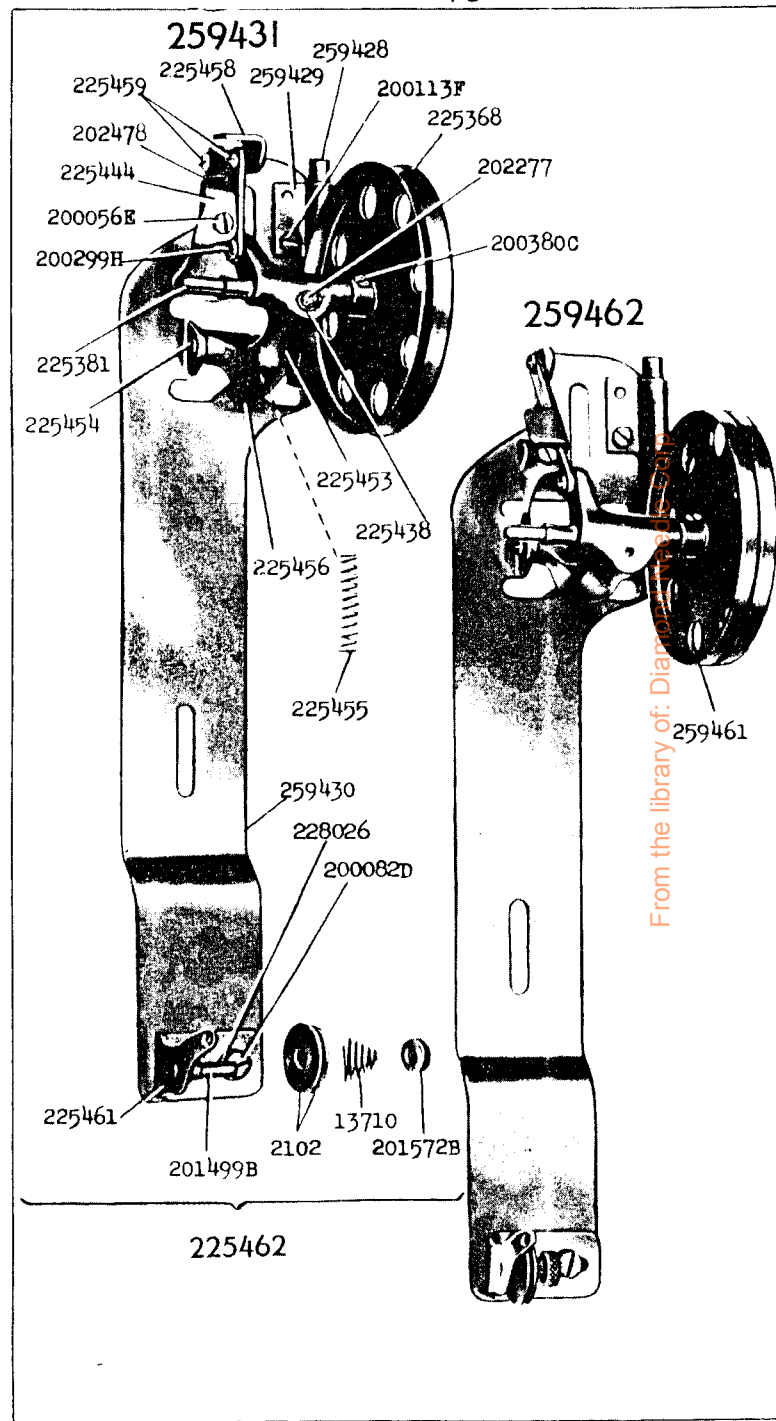



23260 - 1/3

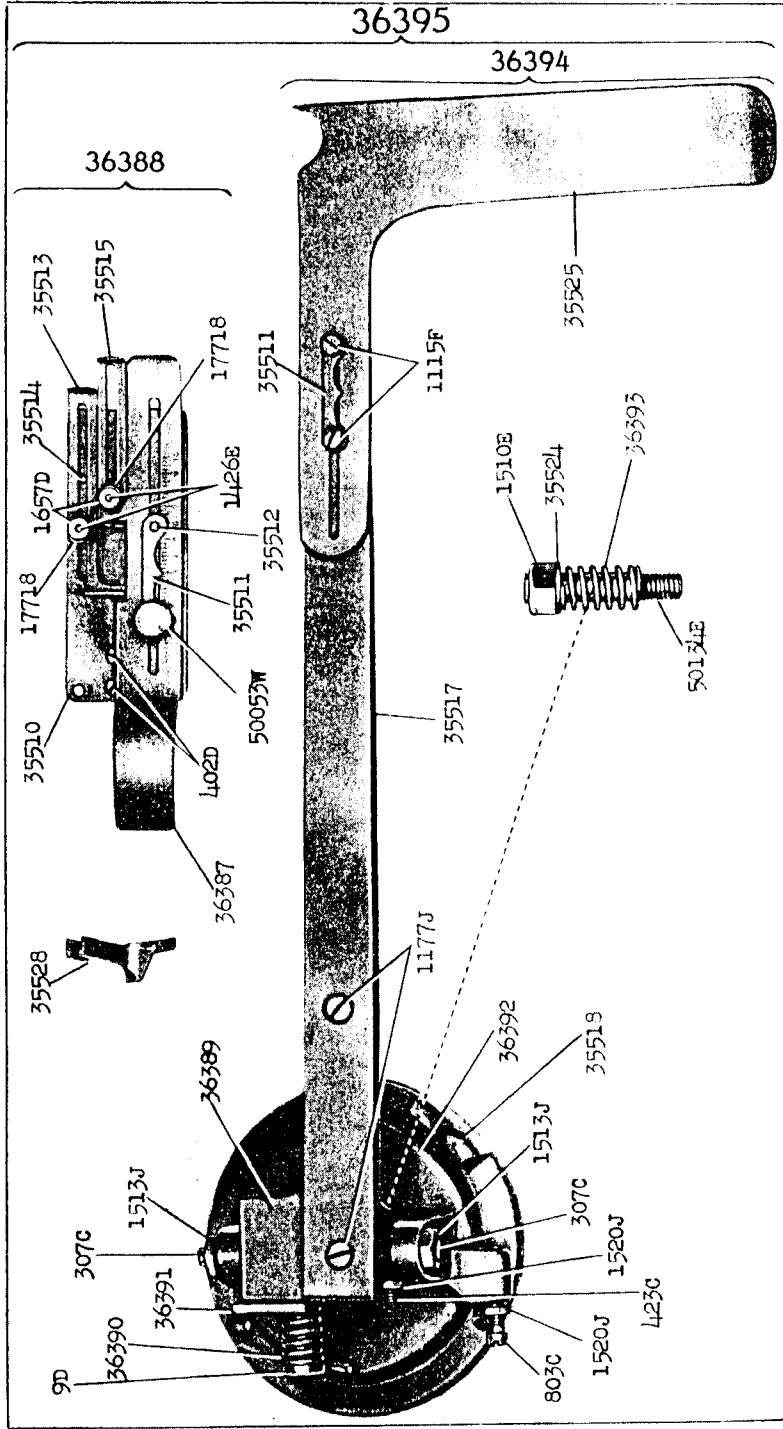

23280 - 2/3

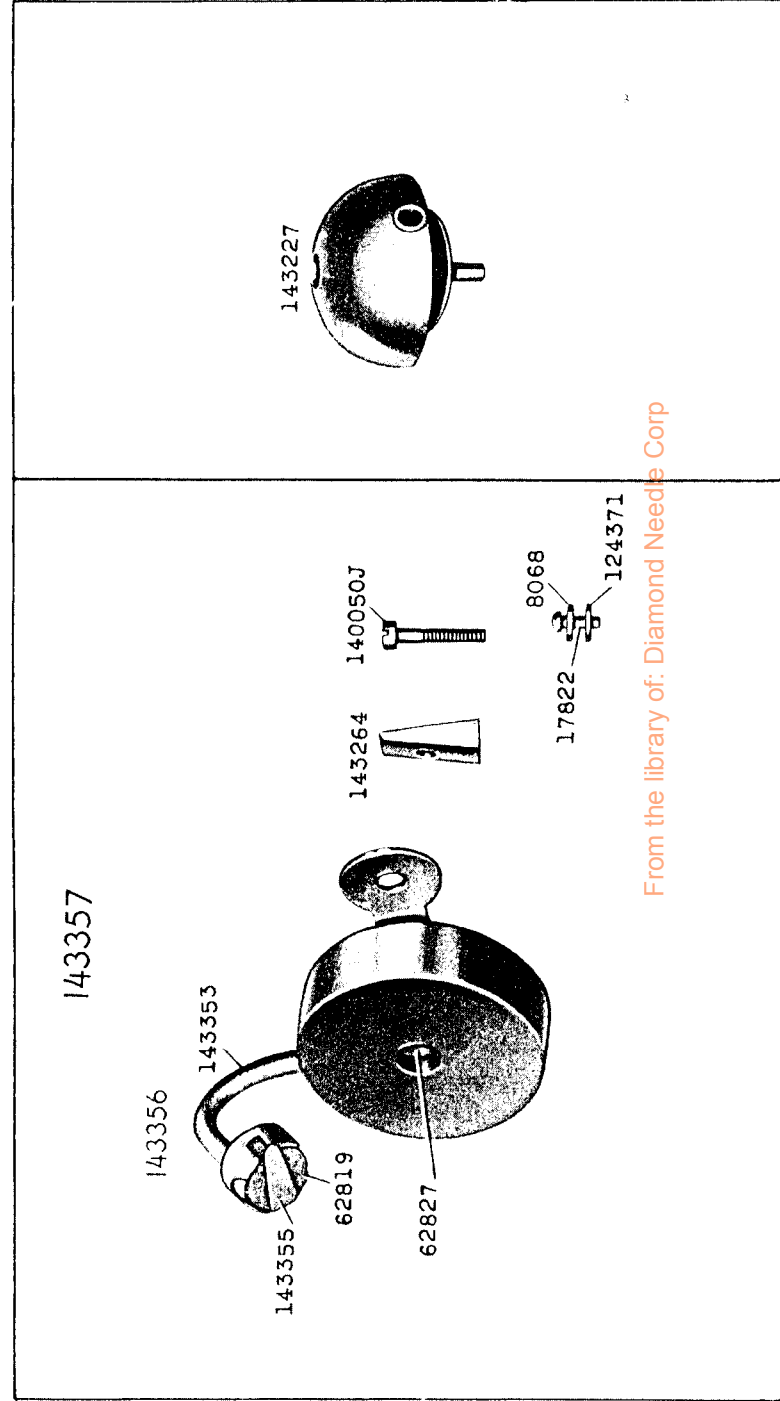

From the library of: Diamond Needle Corp

23289 - 1/4

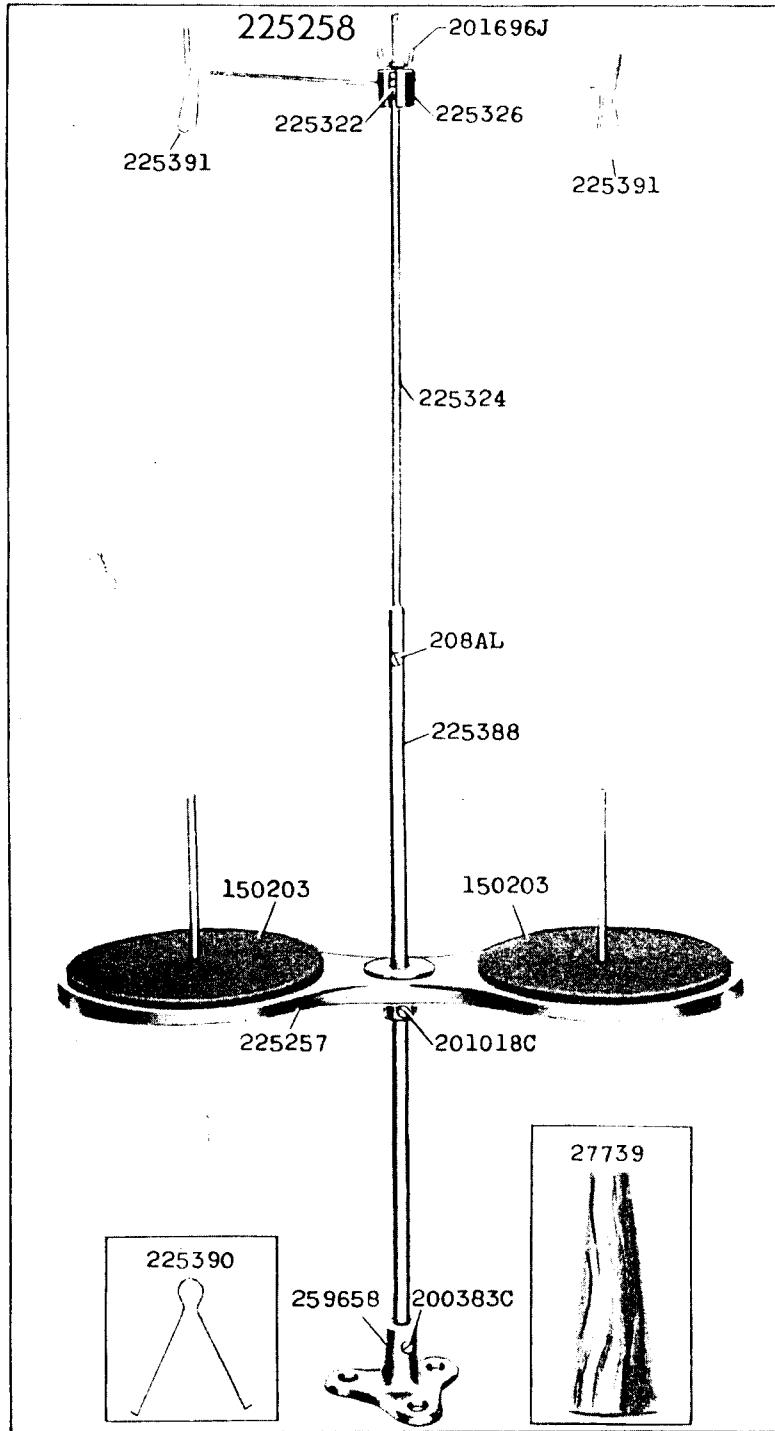

24023 - 1/3

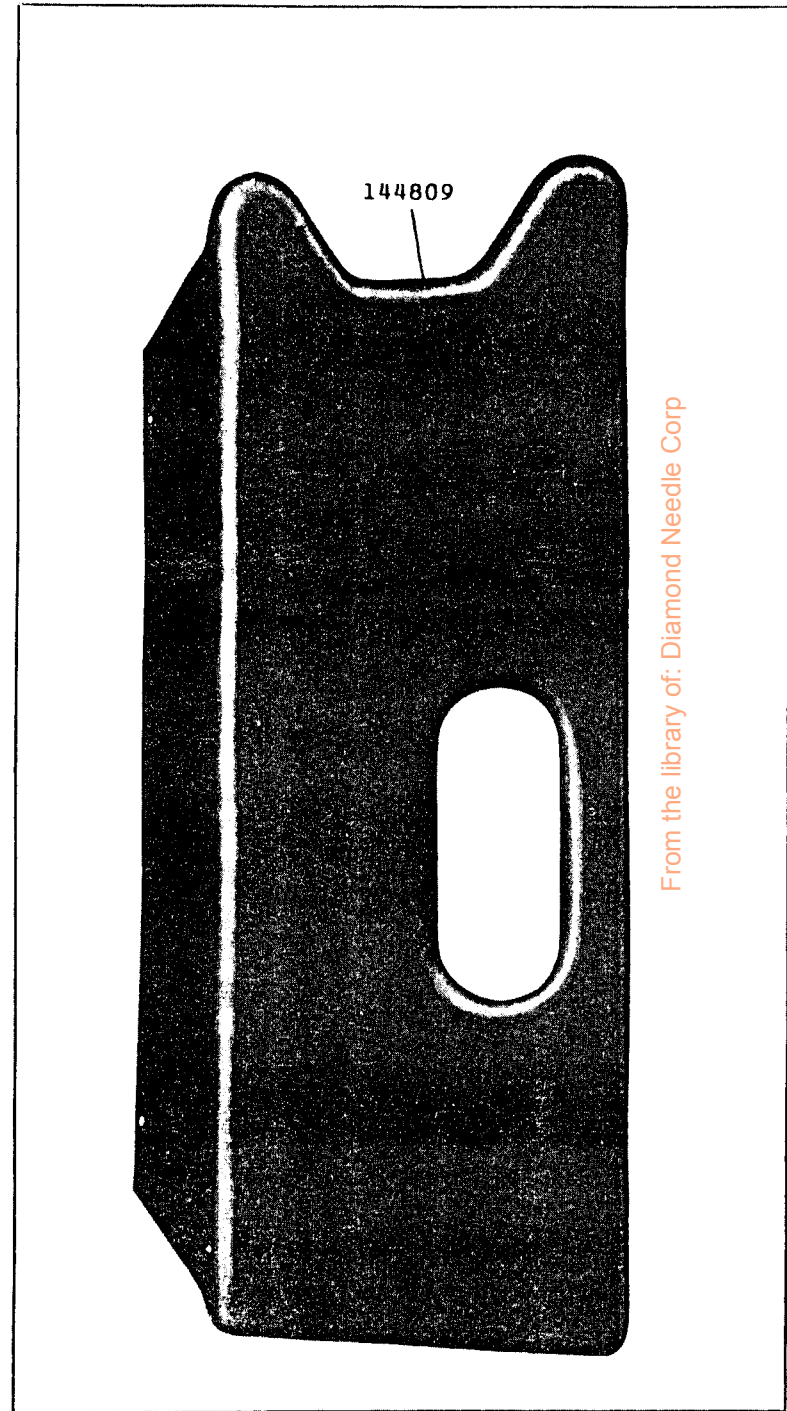

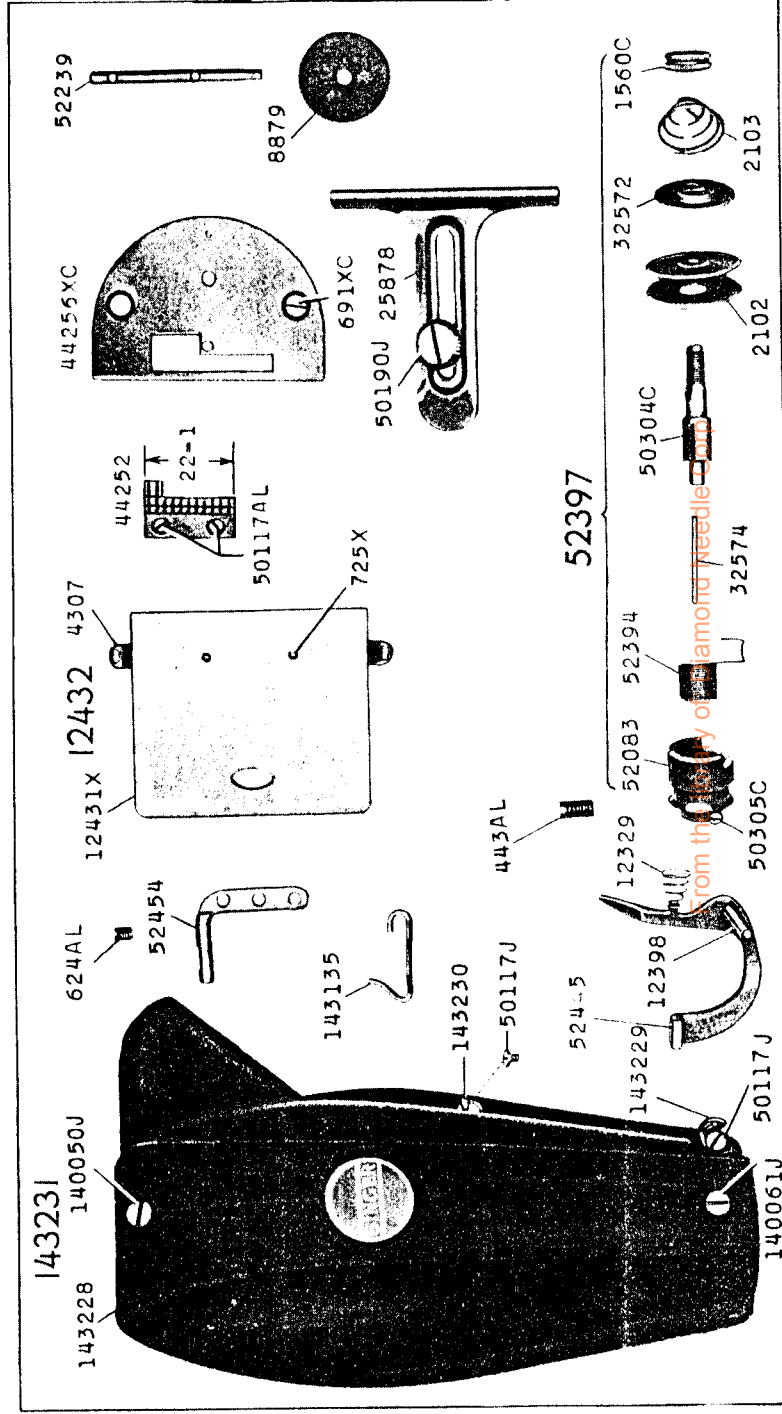
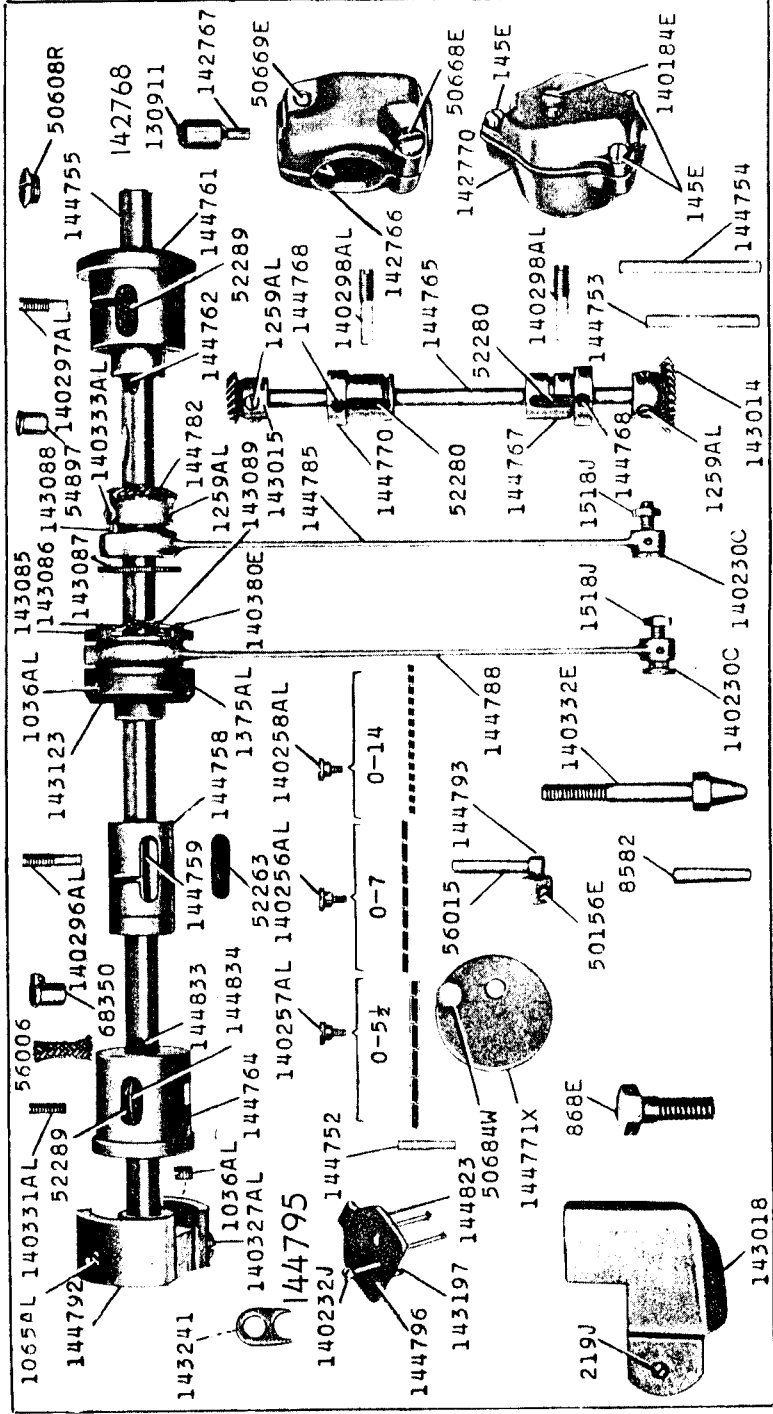

24328 - 1/2

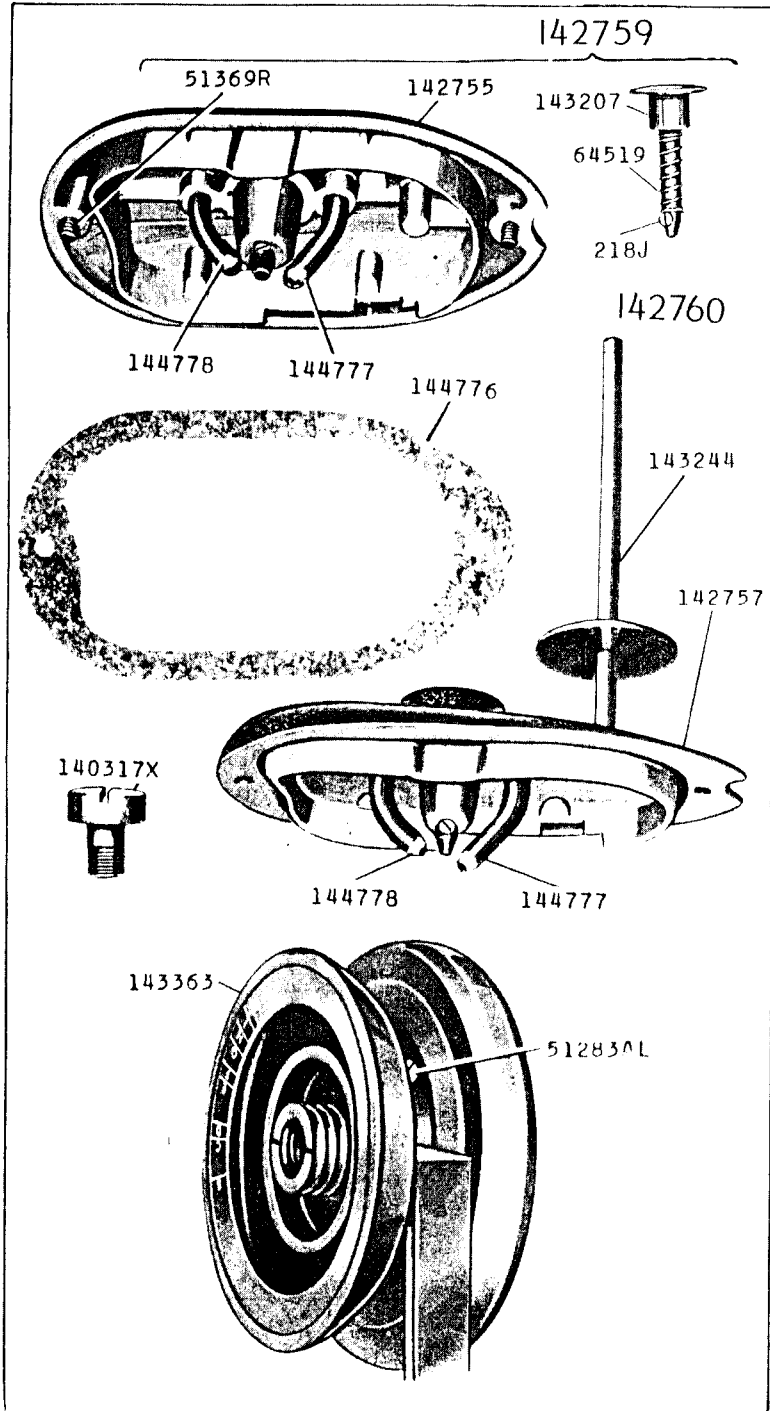

24329 - 1/2

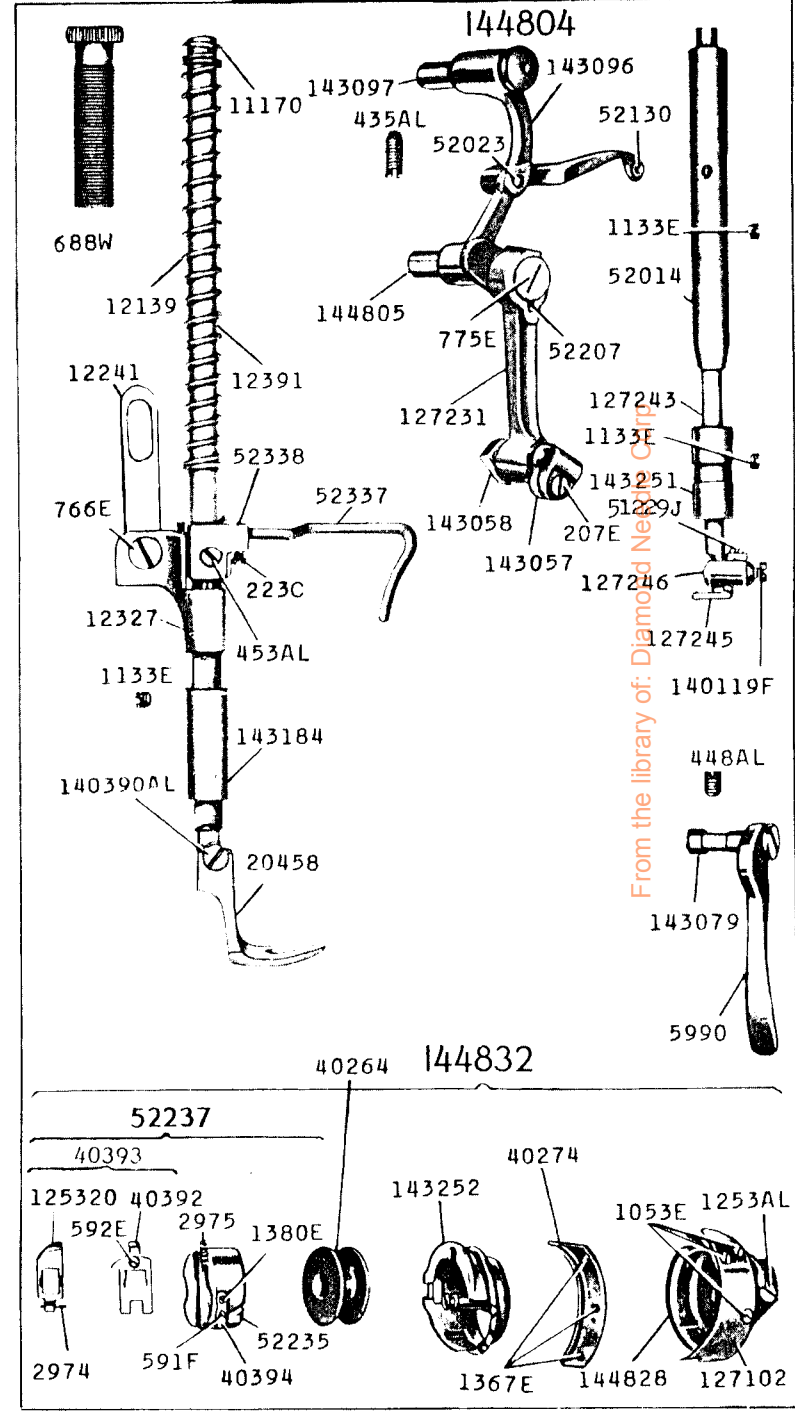

From the library of: Diamond Net

24330 - 1/3

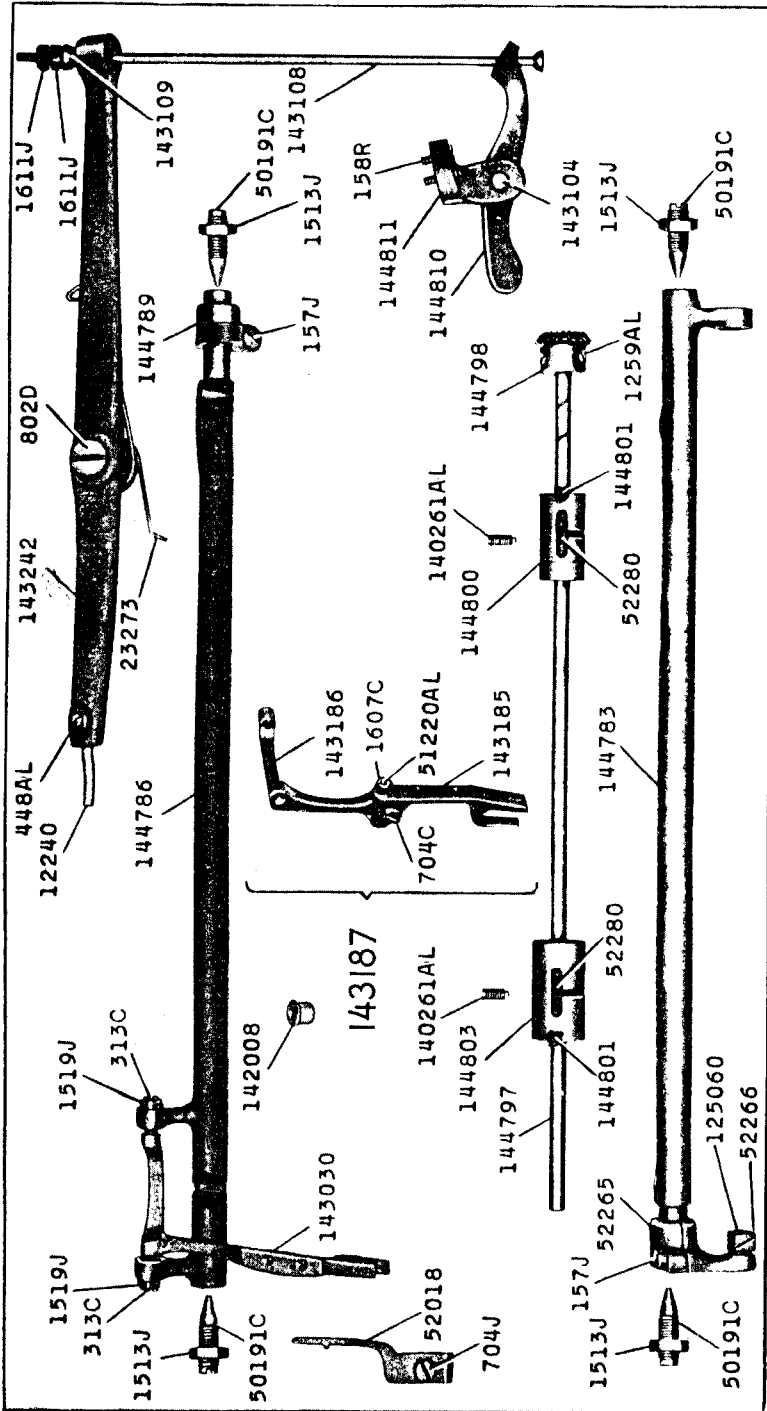

24331 - 2/3

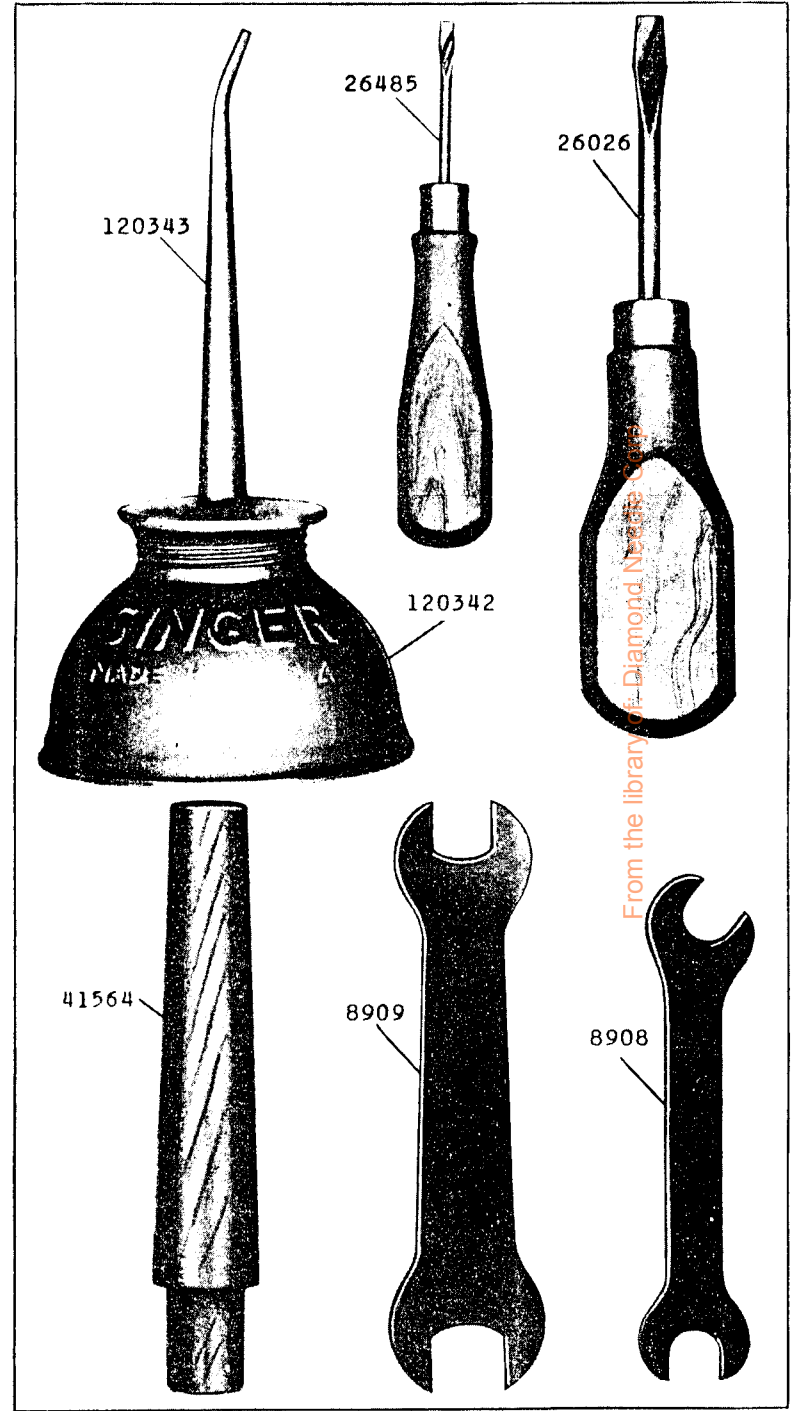

From the library of Diamond Needle Co.

24332 - 2/3

120208



121446

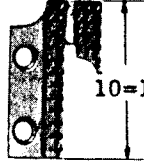

10=1

26605XC

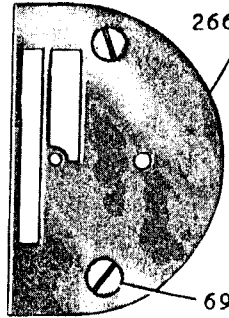

691XC

120207

26795

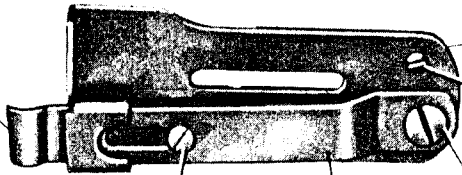

120206

457C

190J

26796

1044D

36294



44252

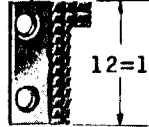

12=1

44256XC

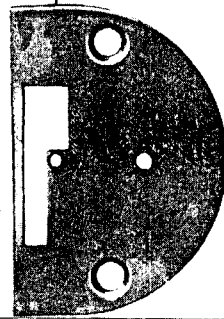

36293

36292

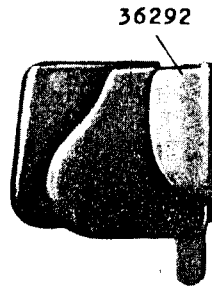

28973

35610

940F

7071

51224W

28972

24333 - 2/3

20120XC

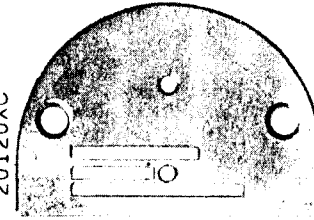

20277XC

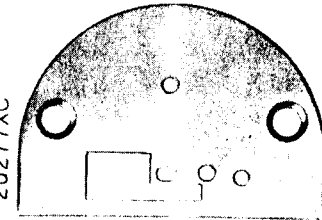

20119

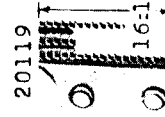

16=1

20275

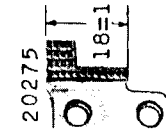

18=1

12259



20276



62927



26231

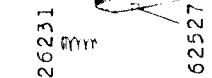

62925



44137XC

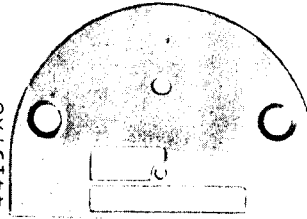

19475XC

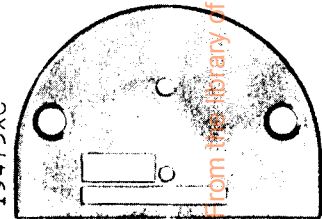

44136

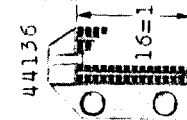

16=1

36906XC

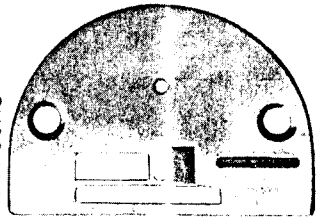

20458



19336

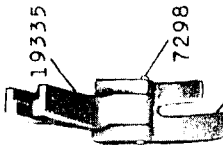

19335

7298

19334

19474

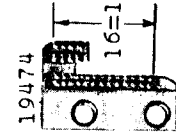

16=1

From the library of: Diamond Needle Corp